

Name: RANDY CATHCART

Date:

Event: LEISURE HOURS JOLIET, IL FUTABA E CHALLENGE

Track Conditions: Outdoor Indoor Wet Dry High Bite Low Bite
 Rough Smooth Hard Packed Loose/Loamy Blue Groove

Bumpsteer/Ackerman/Servo Saver:

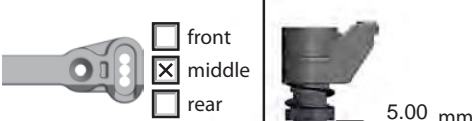

Front End:

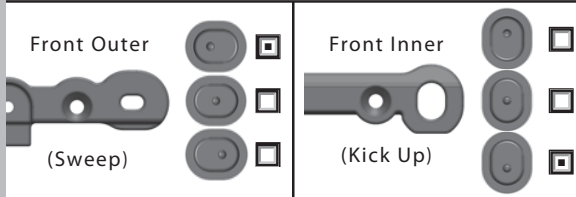
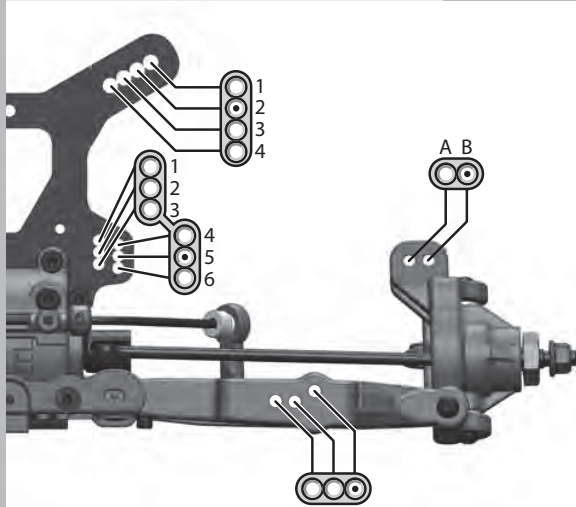

Suspension:

	FRONT	REAR
RIDE HEIGHT	27MM	26MM
CAMBER	1.2	1,5
TOE (in/out)	2	4.5
SWAY BAR	2.5MM	2.5MM
SHOCK LENGTH (DROOP)	105MM	123.5MM

Body/Mounts:

BODY MAKE	TLR PRE CUT
-----------	-------------

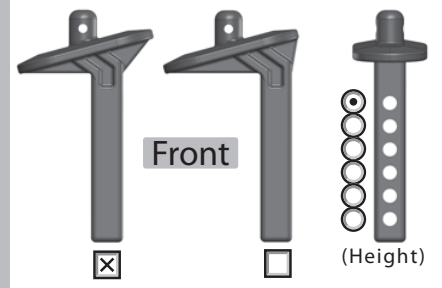

Rear End:

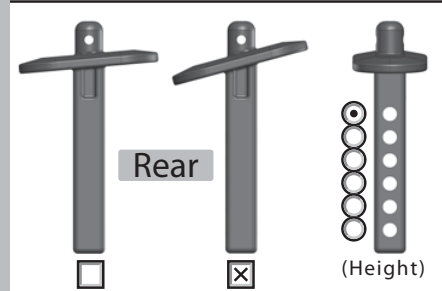
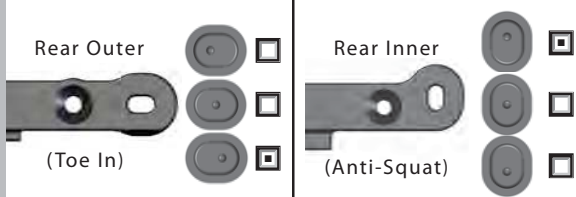
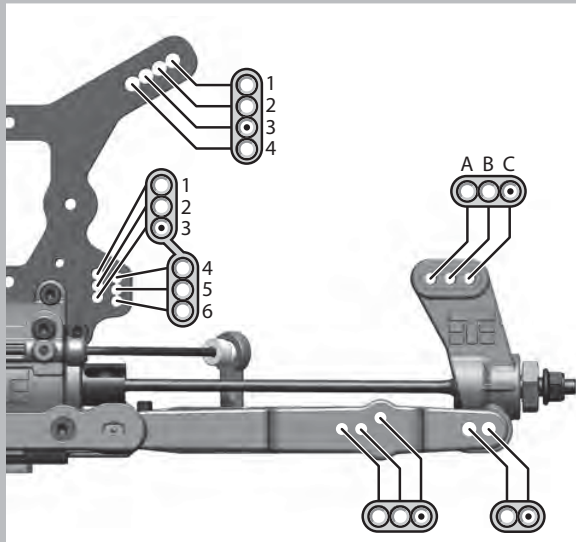

Wheelbase:

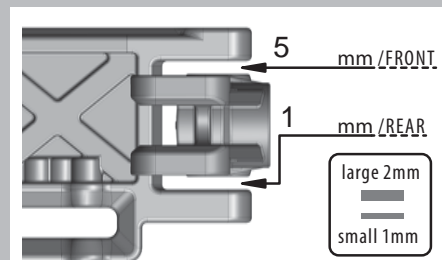

Notes:

BATTERY BACK 20MM, PLUS 1.5 REAR TOE BLOCK, DELRIN SHOCK BUSHINGS, ALL LIGHWEIGHT OPTION PARTS,
 3/4OZ LEAD BETWEEN FRONT STEERING POST 1 OZ LEAD BEHIND REAR DIFF
 TRACK HAD 90-180+ SWEEPING TURNS 3 BIG TRIPLES A LIGHT BLUE GROOVE WEATHER WAS SUNNY 80° DAY AND 69° NIGHT

Shocks:

	FRONT	REAR
OIL	AE 35	AE 27
PISTON	8X1.4	8X1.4
SPRING	BLACK	PINK
REBOUND	5 %	5 %
STD/EMUL/VENT	VENT/BLADDER	VENT/BLADDER

Tires / Wheels:

	FRONT	REAR
BRAND/TREAD	PROLINE BLOCKADES	
COMPOUND	M3 / M4	
INSERT	STOCK	
WHEEL	DE	

NOTES: M3 DURING DAY M4 AT NIGHT

Differential Oil:

FRONT	CENTER	REAR
AE 5K	AE 5K	AE 2K

Electronics:

ESC:	TEKIN GEN2
Battery:	TRAKPOWER 7200 90C
Motor:	HOBBY WING 4700
Radio:	MT-4
Servo:	JR 9100 HVS

Drivetrain:

SPUR GEAR	Metal <input type="checkbox"/> Composite <input checked="" type="checkbox"/>
Traktion Drive	<input type="checkbox"/> Elektri-Clutch <input type="checkbox"/> Pinion <input checked="" type="checkbox"/>
PINION SIZE	16 (teeth)
Mechanical Brakes	<input type="checkbox"/> Motor Brakes <input checked="" type="checkbox"/>

Chassis Braces:

Front Middle Rear
 (front brace is always recommended)