

Name: PRES ILOG

Date:

Event: SC SHOWDOWN @ HOBBYPLEX

Track Conditions: Outdoor Indoor Wet Dry High Bite Low Bite
 Rough Smooth Hard Packed Loose/Loamy Blue Groove

Bumpsteer/Ackerman/Servo Saver:

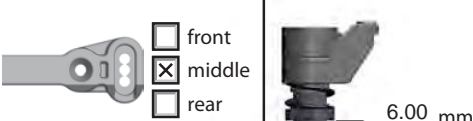

Front End:

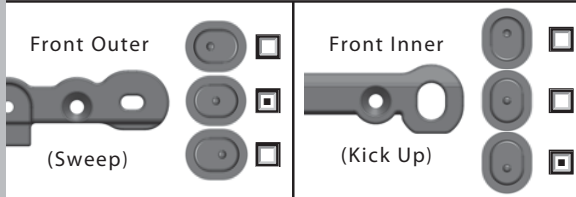
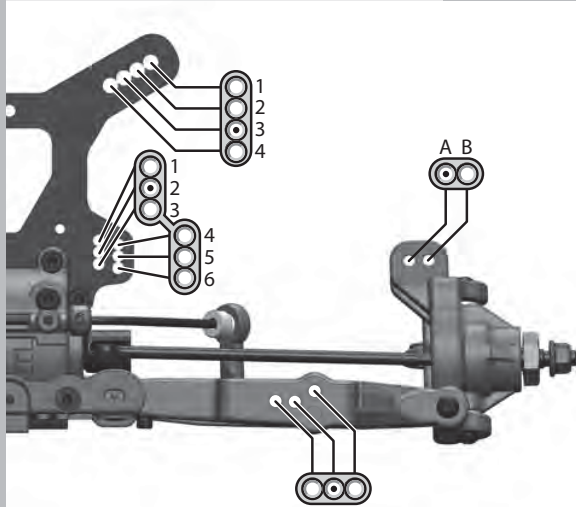

Suspension:

	FRONT	REAR
RIDE HEIGHT	24MM	24MM
CAMBER	-2	-2
TOE (in/out)	2 OUT	
SWAY BAR	2.4MM	2.2MM
SHOCK LENGTH (DROOP)	104MM	112MM

Body/Mounts:

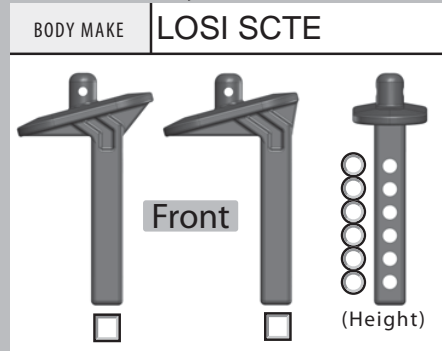

Rear End:

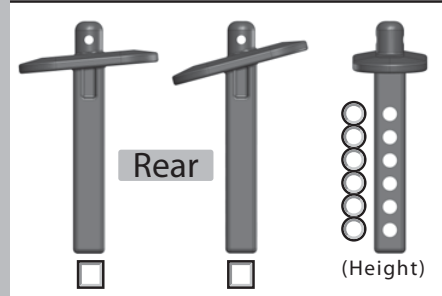
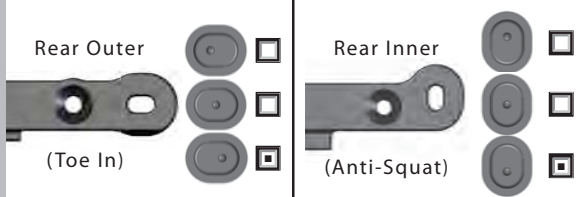
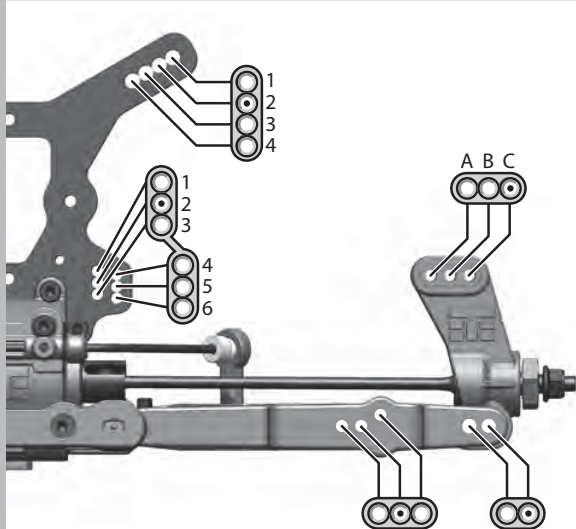

Wheelbase:

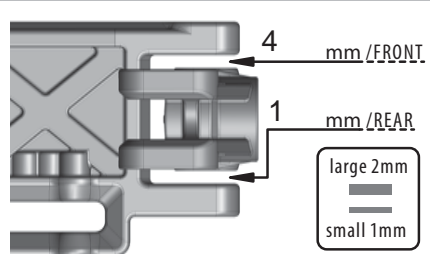

Notes:

MEDIUM BITE/CHOPPY IN AREAS. 1976 GRAMS LESS BODY, BATTERY, TIRES.
 FULL TITANIUM/ALUMINUM SCREWS. FRONT SHOCK BODY, SPRINGS, AND
 TOWER USED ON REAR TO REDUCE WEIGHT. BATTERY TRAY MODDED AND FULL REAR.

Shocks:

	FRONT	REAR
OIL	30 LOSI	27.5 LOSI
PISTON	8 X 1.3	8 X 1.3
SPRING	PINK	GREY
REBOUND	0 %	0 %
STD/EMUL/VENT	BLADDER/VENTED	BLADDER/VENTED

Tires / Wheels:

	FRONT	REAR
BRAND/TREAD	AKA SLINGSHOTS	AKA SLINGSHOTS
COMPOUND	SUPER SOFT	SUPER SOFT
INSERT	AKA RED	AKA RED
WHEEL	AKA 23006	AKA 23006

NOTES:

Differential Oil:

FRONT	CENTER	REAR
PTRC 5K	6K	4K

Electronics:

ESC:	HOBBYWING
Battery:	THUNDERPOWER
Motor:	HOBBYWING 4000KV
Radio:	KO PROPO
Servo:	HITEC 7940

Drivetrain:

SPUR GEAR	Metal <input type="checkbox"/> Composite <input checked="" type="checkbox"/>
Traktion Drive	<input type="checkbox"/> Elektri-Clutch <input type="checkbox"/> Pinion <input checked="" type="checkbox"/>
PINION SIZE	18 (teeth)
Mechanical Brakes	<input type="checkbox"/> Motor Brakes <input checked="" type="checkbox"/>

Chassis Braces:

Front Middle Rear
 (front brace is always recommended)