

Name: Austin Blair

Date:

Event: DNC

Track Conditions: Outdoor Indoor Wet Dry High Bite Low Bite
 Rough Smooth Hard Packed Loose/Loamy Blue Groove

Bumpsteer/Ackerman/Servo Saver:

washers over 1 under 2

washers over 4 under 0



front middle rear

mm



Front End:

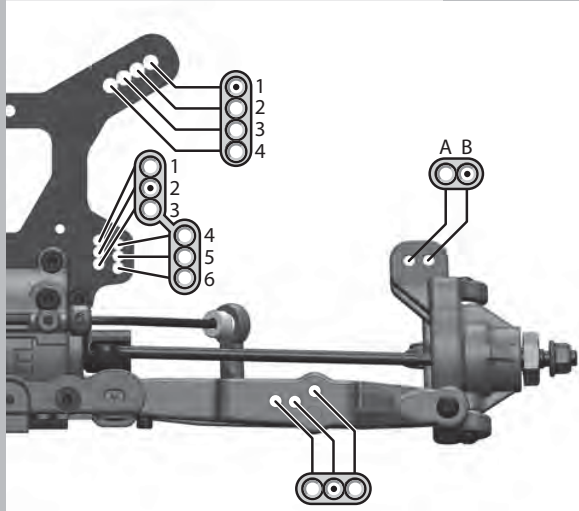

Front Outer (Sweep)

Front Inner (Kick Up)

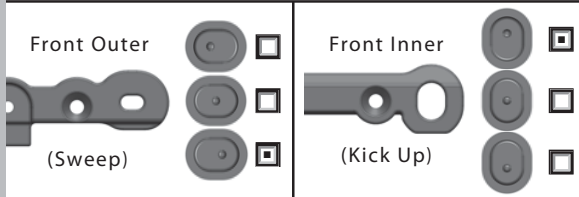

Suspension:

	FRONT	REAR
RIDE HEIGHT	28	28
CAMBER	1	1
TOE (in/out)	1 out	4.5
SWAY BAR	2.2	2.2
SHOCK LENGTH (DROOP)	101	119

Body/Mounts:

BODY MAKE	Proline Ford Raptor
-----------	---------------------

Front

(Height)

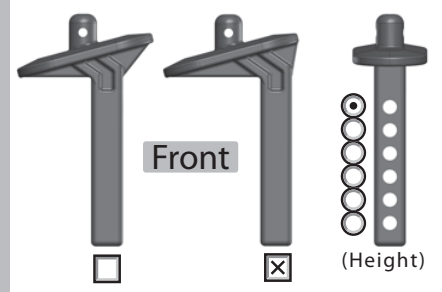

Rear End:

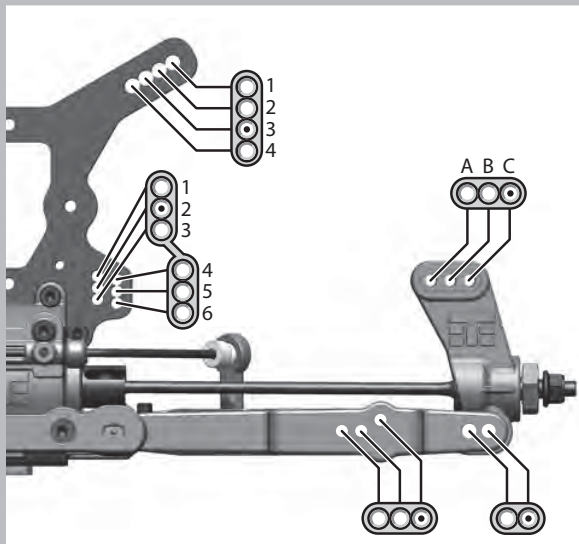

Rear Outer (Toe In)

Rear Inner (Anti-Squat)

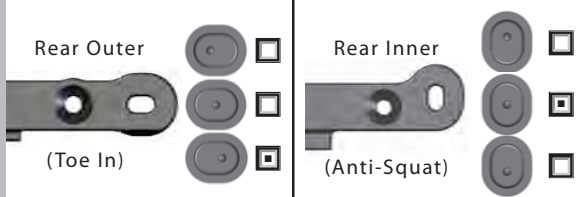

Rear

(Height)

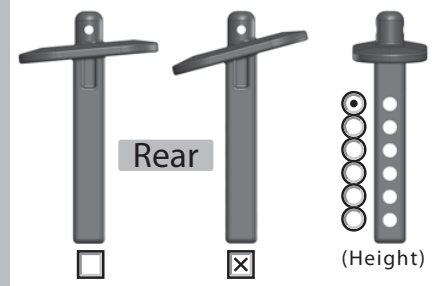

Wheelbase:

2 mm / FRONT

3 mm / REAR

large 2mm

small 1mm

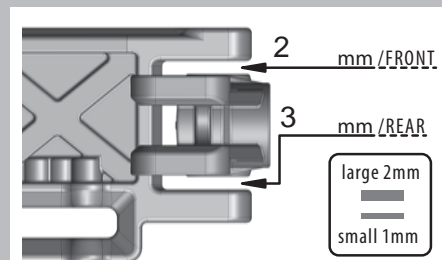

Notes:

Light Weight chassis, LW center drive shaft, LW outdrives, LW suspension balls
 Aluminum hexes.

Shocks:

	FRONT	REAR
OIL	35	30
PISTON	10hole 1.2	10hole 1.2
SPRING	pink	pink
REBOUND	0 %	0 %
STD/EMUL/VENT	std	std

Tires / Wheels:

	FRONT	REAR
BRAND/TREAD	Aka city blocks	aka city blocks
COMPOUND	ss	ss
INSERT	aka red	aka red
WHEEL	aka cyclone	aka cyclone

NOTES:

Differential Oil:

FRONT	CENTER	REAR
7	5	3

Electronics:

ESC:	Tekin Rx8
Battery:	ProTek 7000mah 100c
Motor:	Tekin 4600kv
Radio:	M11x
Servo:	ProTek 150s

Drivetrain:

SPUR GEAR	Metal <input type="checkbox"/> Composite <input checked="" type="checkbox"/>
Traktion Drive	<input type="checkbox"/> Elektri-Clutch <input type="checkbox"/> Pinion <input checked="" type="checkbox"/>
PINION SIZE	15 (teeth)
Mechanical Brakes	<input type="checkbox"/> Motor Brakes <input checked="" type="checkbox"/>

Chassis Braces:

Front <input checked="" type="checkbox"/>	Middle <input type="checkbox"/>	Rear <input type="checkbox"/>
(front brace is always recommended)		