



Name: Joe Bornhorst

Date: 8/16/15

Event/Track: Wicked Weekend

Track Conditions: Outdoor Indoor Wet Dry High Bite Low Bite Rough
 Smooth Hard Packed Loose/Loamy Blue Groove

Bumpsteer/Ackerman/Servo Saver/Steering Stop:

 <p># washers 4 over under ballstud</p>	 <p># washers 4 over under ballstud</p>	 <p><input type="checkbox"/> front <input type="checkbox"/> middle <input type="checkbox"/> rear</p>
---	--	---

Front End:

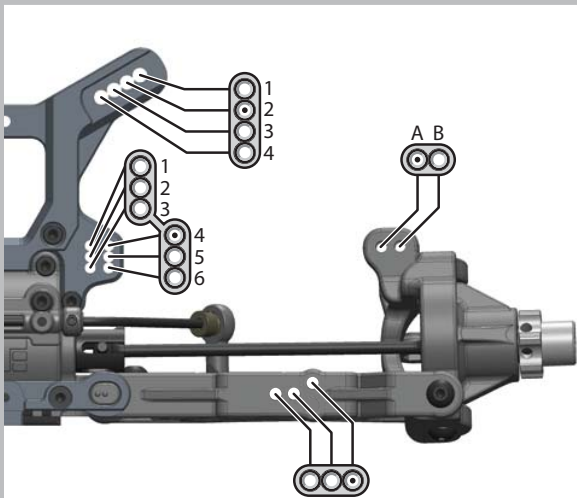

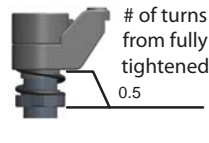
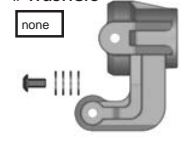
 <p># of turns from fully tightened 0.5</p>	 <p># washers none</p>
--	--

Suspension:

	FRONT	REAR
RIDE HEIGHT:	38	41
TOE (in/out):	1 out	3.5
CAMBER:	-2	-2
CASTER:	15 trail deg	
SHOCK LENGTH (DROOP):	121	136
SWAY BAR:	2.6	2.8

NOTES:

Body/Wing:

BODY:	Tekno
WING:	Tekno

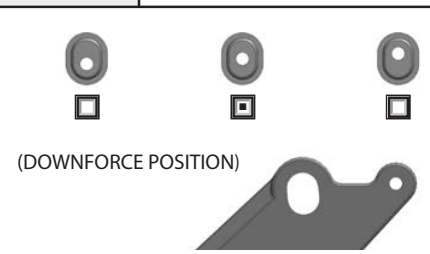

(DOWNFORCE POSITION)

Wheelbase:

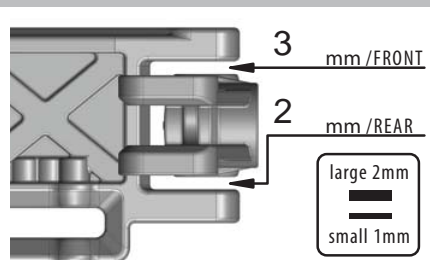

Notes:

New square pills.
 A Brace: Dot Down
 C Brace (Old Brace to achieve more anti squat): Dot up

	FRONT	REAR
STD/EMUL/VENT:	non vent	non vent
PISTON:	losi 8x1.3	losi 8x1.3
OIL:	700	600
BLADDER:	stk	stk
REBOUND:	min %	min %
SPRING:	green	orange

NOTES:

Tires / Wheels:

	FRONT	REAR
BRAND:	AKA	AKA
TREAD:	Impact	Impact
COMPOUND:	Soft	Soft
INSERT:	Red	Red
WHEEL:	Evo	Evo

NOTES:

Differential Oil:

	FRONT	CENTER	REAR
10k		15k	7k

NOTES:

Equipment:

ENGINE:	O.S. XZB Spec II
PIPE:	O.S. 2090
PLUG:	O.S. P3
FUEL:	Byrons 30-8
RX BATT:	SMC
SERVO:	steering Highest / throttle/brake Highest

Drivetrain:

CLUTCH/SPUR:	13 / 46 (teeth)
CLUTCH SHOES:	4 alu
CLUTCH SPRINGS:	4 yellow
ENGINE POSITION:	Front <input checked="" type="checkbox"/> Rear <input type="checkbox"/>
BRAKE BIAS:	60% front / 40% rear

Chassis Braces:

Center Rear Left Rear Right

Front Outer (Sweep)



1.0F 0.5F 0.0 0.5R 1.0R

Front Inner (Kick Up)



10.0° 10.5° 11.0° 11.5° 12.0°

Rear End:

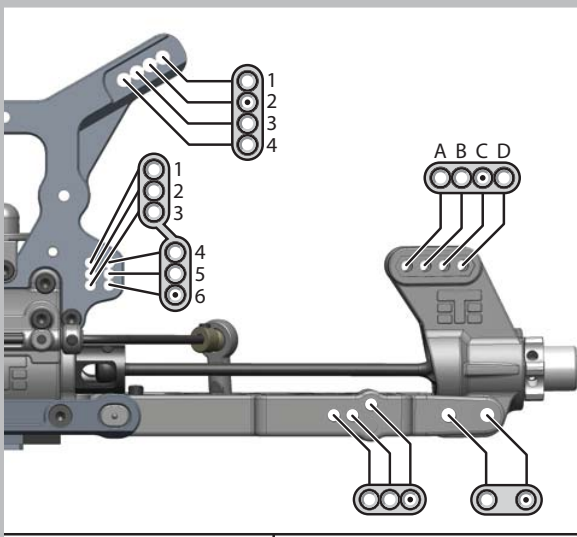

Rear Outer (Toe In)

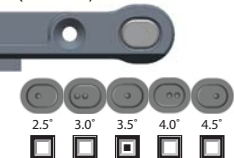

2.5° 3.0° 3.5° 4.0° 4.5°

Rear Inner (Anti-Squat)



3.0° 2.5° 2.0° 1.5° 1.0°