



Name: Darren Lord

Date: 20th of July 2014 Event/Track: Australian titles Meakin Park

Track Conditions: Outdoor  Indoor  Wet  Dry  High Bite  Low Bite  Rough   
 Smooth  Hard Packed  Loose/Loamy  Blue Groove

### Bumpsteer/Ackerman/Servo Saver/Steering Stop:

 <p># washers 4 over under ballstud</p>	 <p># washers 4 over under ballstud</p>	 <p><input type="checkbox"/> front <input checked="" type="checkbox"/> middle <input type="checkbox"/> rear</p>
-------------------------------------------------------------------------------------------------------------------------------------	--------------------------------------------------------------------------------------------------------------------------------------	----------------------------------------------------------------------------------------------------------------------------------------------------------------------------------------------------------

### Front End:

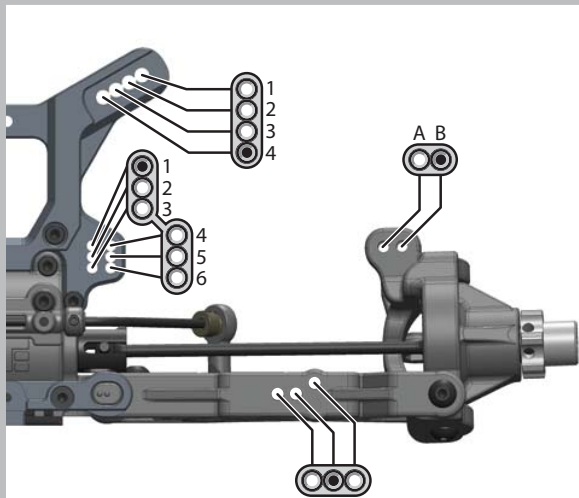

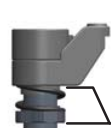
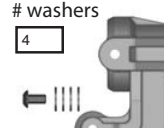
 <p># of turns from fully tightened 4</p>	 <p># washers 4</p>
--------------------------------------------------------------------------------------------------------------------------------	-----------------------------------------------------------------------------------------------------------

### Suspension:

	FRONT	REAR
RIDE HEIGHT:	35	36
TOE (in/out):	1.5 out	3.5 in
CAMBER:	2	2
CASTER:	15 Deg°	
SHOCK LENGTH (DROOP):	121	136
SWAY BAR:	2.6	2.6

NOTES:

### Body/Wing:

BODY:	Stock NT48
WING:	Stock Tekno

(DOWNFORCE POSITION)

### Wheelbase:

0 mm /FRONT  
5 mm /REAR  
large 2mm  
small 1mm

Notes:

	FRONT	REAR
STD/EMUL/VENT:	Emul	Emul
PISTON:	Fioroni	Fioroni
OIL:	45	40
BLADDER:	No	No
REBOUND:	5 %	5 %
SPRING:	Green	Green

NOTES:

### Tires / Wheels:

	FRONT	REAR
BRAND:	Panther	Panther
TREAD:	Raptors	Raptors
COMPOUND:	Super soft	Super soft
INSERT:	Yellow panther	Yellow panther
WHEEL:	TLR	TLR

NOTES:

### Differential Oil:

	FRONT	CENTER	REAR
	10	10	5

NOTES:

### Equipment:

ENGINE:	Picco Team Spec
PIPE:	Picco 2099
PLUG:	P3
FUEL:	Podified 25%
RX BATT:	Smc 2000
SERVO:	steering / throttle/brake Kopropo / Kopropo

### Drivetrain:

CLUTCH/SPUR:	13 / 48 (teeth)
CLUTCH SHOES:	Stock
CLUTCH SPRINGS:	2 x 0.9 & 2 x 1.0
ENGINE POSITION:	Front <input checked="" type="checkbox"/> Rear <input type="checkbox"/>

BRAKE BIAS:	65 % front	35 % rear
-------------	------------	-----------

### Chassis Braces:

Center <input checked="" type="checkbox"/> Rear Left <input checked="" type="checkbox"/> Rear Right <input type="checkbox"/>
------------------------------------------------------------------------------------------------------------------------------

### Front Outer (Sweep)

1.0F 0.5F 0.0 0.5R 1.0R

### Front Inner (Kick Up)

10.0 10.5 11.0 11.5 12.0

### Rear End:

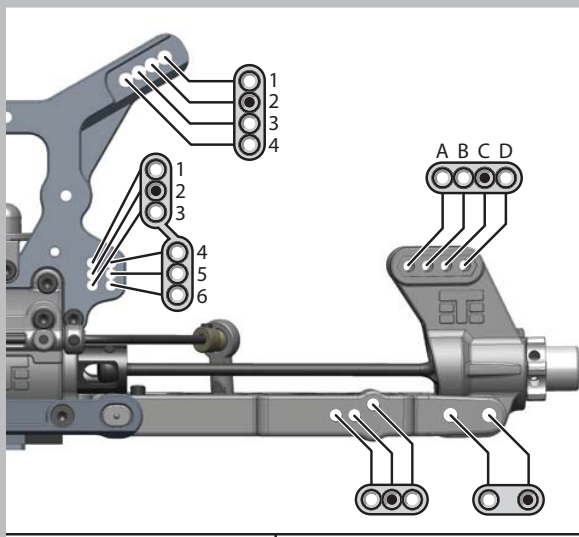

### Rear Outer (Toe In)

2.5 3.0 3.5 4.0 4.5

### Rear Inner (Anti-Squat)

3.0 2.5 2.0 1.5 1.0