



Name: Matt Wolter

Date: 10/6/2014

Event/Track: Southern Nats

Track Conditions: Outdoor Indoor Wet Dry High Bite Low Bite Rough
 Smooth Hard Packed Loose/Loamy Blue Groove

Bumpsteer/Ackerman/Servo Saver/Steering Stop:

 <p># washers <input type="checkbox"/> over <input type="checkbox"/> under ballstud <input type="checkbox"/></p>	 <p># washers <input type="checkbox"/> over <input type="checkbox"/> under ballstud <input type="checkbox"/></p>	 <p><input type="checkbox"/> front <input checked="" type="checkbox"/> middle <input type="checkbox"/> rear</p>
---	--	---

Front End:

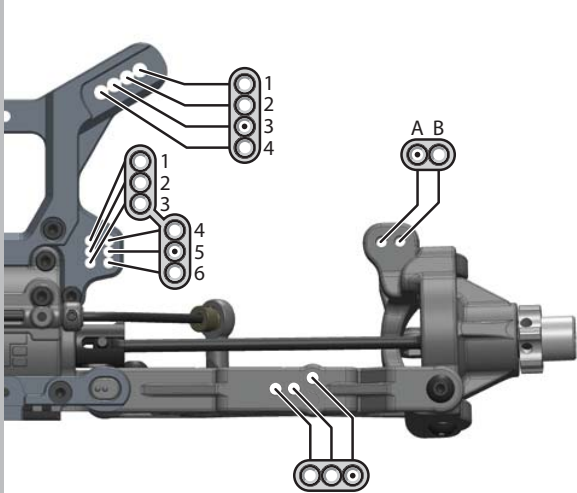

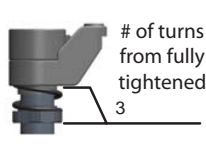
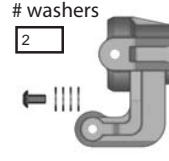
 <p># of turns from fully tightened <input type="checkbox"/> 3</p>	 <p># washers <input type="checkbox"/> 2</p>
--	---

Suspension:

	FRONT	REAR
RIDE HEIGHT:	38	38
TOE (in/out):	+1	
CAMBER:	-2	-2
CASTER:	10 Deg°	
SHOCK LENGTH (DROOP):	122	133
SWAY BAR:	2.6	2.6

NOTES:

Body/Wing:

BODY:	Stock
WING:	Stock

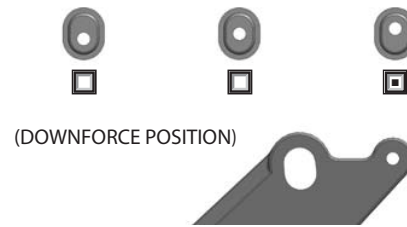

(DOWNFORCE POSITION)

Wheelbase:

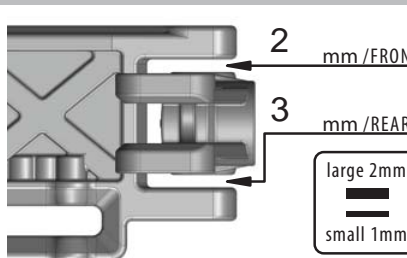

2 mm / FRONT
 3 mm / REAR
 large 2mm
 small 1mm

Notes:

FRONT REAR

STD/EMUL/VENT:	STD	STD
PISTON:	6.5	6.5
OIL:	650	600
BLADDER:	Yes	Yes
REBOUND:	75 %	75 %
SPRING:	Green	Green

NOTES:

Tires / Wheels:

	FRONT	REAR
BRAND:	Proline	
TREAD:	Holeshot	
COMPOUND:	M3	
INSERT:	Blue	
WHEEL:		

NOTES:

Differential Oil:

	FRONT	CENTER	REAR
	12	15	7

NOTES:

Equipment:

ENGINE:	LRP ZZ.21c Spec 2
PIPE:	OS 2090
PLUG:	P3
FUEL:	
RX BATT:	LRP 2600
SERVO:	steering Savox 2273 / throttle/brake Highest DT2100

Drivetrain:

CLUTCH/SPUR:	13 / (teeth)
CLUTCH SHOES:	Buku Komposite
CLUTCH SPRINGS:	0-1-2
ENGINE POSITION:	Front <input checked="" type="checkbox"/> Rear <input type="checkbox"/>
BRAKE BIAS:	55 ^{front} % 45 ^{rear} %

Chassis Braces:

Center Rear Left Rear Right

Front Outer (Sweep)

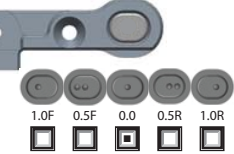

1.0F 0.5F 0.0 0.5R 1.0R

Front Inner (Kick Up)



10.0° 10.5° 11.0° 11.5° 12.0°

Rear End:

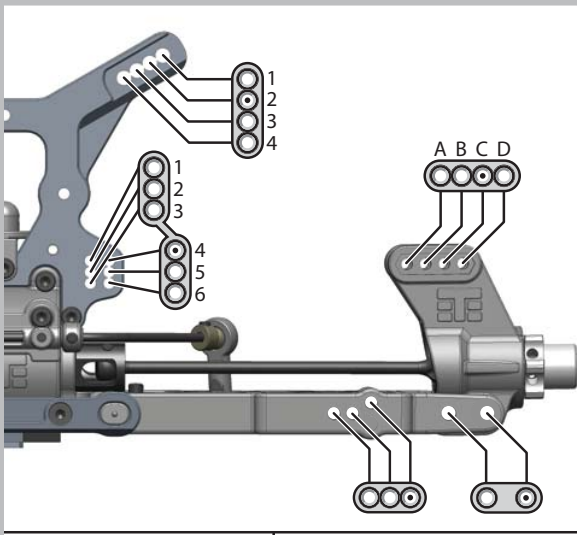

Rear Outer (Toe In)

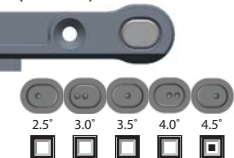

2.5° 3.0° 3.5° 4.0° 4.5°

Rear Inner (Anti-Squat)



3.0° 2.5° 2.0° 1.5° 1.0°