



Name: Ryan Lutz

Date: 11-16-14

Event/Track: Battle of the Sikest @ Fear Farm

Track Conditions: Outdoor  Indoor  Wet  Dry  High Bite  Low Bite  Rough   
 Smooth  Hard Packed  Loose/Loamy  Blue Groove

### Bumpsteer/Ackerman/Servo Saver/Steering Stop:

 <p># washers  <input type="checkbox"/> over  <input type="checkbox"/> under                  ballstud  <input type="checkbox"/> <input checked="" type="checkbox"/></p>	 <p># washers  <input type="checkbox"/> over  <input type="checkbox"/> under                  ballstud  <input checked="" type="checkbox"/> <input type="checkbox"/></p>	 <p><input type="checkbox"/> front  <input type="checkbox"/> middle  <input checked="" type="checkbox"/> rear</p>
--	---	--

### Front End:

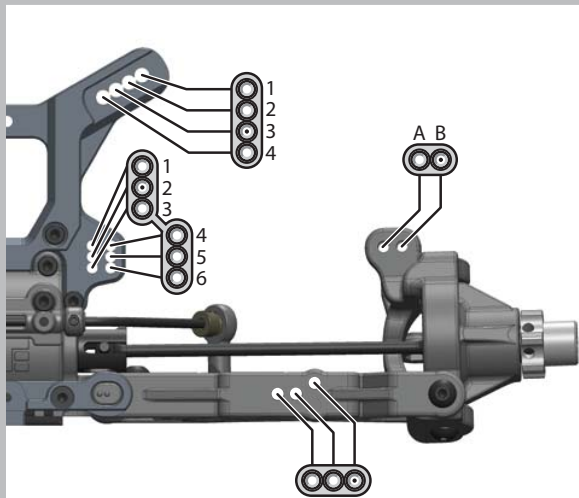

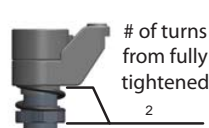
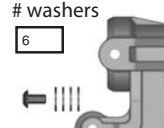
 <p># of turns from fully tightened  <input type="checkbox"/> 2</p>	 <p># washers  <input type="checkbox"/> 6</p>
--	---

### Suspension:

	FRONT	REAR
RIDE HEIGHT:	27	27.5
TOE (in/out):	1° Out	3°
CAMBER:	-2°	-2°
CASTER:	15 Deg°	
SHOCK LENGTH (DROOP):	107	122
SWAY BAR:	2.6	2.5

NOTES:

### Body/Wing:

BODY:	Stock
WING:	Stock

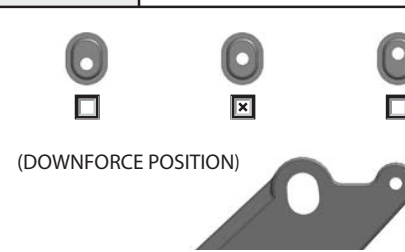

(DOWNFORCE POSITION)

### Wheelbase:

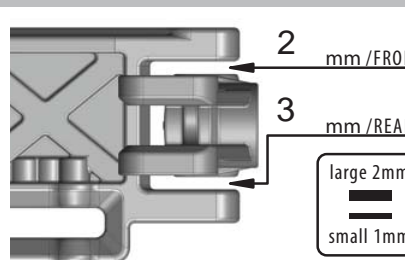

2 mm / FRONT  
 3 mm / REAR  
 large 2mm  
 small 1mm

Notes:

LRC

	FRONT	REAR
STD/EMUL/VENT:	Vent	Vent
PISTON:	6x1.5	6x1.5
OIL:	450	350
BLADDER:	Grey	Grey
REBOUND:	10 %	10 %
SPRING:	Pink	Red

NOTES:

### Tires / Wheels:

	FRONT	REAR
BRAND:	AKA	AKA
TREAD:	Impact	Impact
COMPOUND:	Soft	Soft
INSERT:	AKA Red	AKA Red
WHEEL:	AKA Evo	AKA Evo

NOTES: S during day, SS at night

### Differential Oil:

	FRONT	CENTER	REAR
	7k	7k	5k

NOTES: PT RC Oils

### Equipment:

ENGINE:	Alpha Lutz Worlds
PIPE:	Alpha Lutz 2107
PLUG:	LutzRC L4
FUEL:	Byrons 35/8
RX BATT:	ProTek 2600
SERVO:	steering S9353HV / throttle/brake S9353HV

### Drivetrain:

CLUTCH/SPUR:	15 / 44 (teeth)
CLUTCH SHOES:	Aluminum
CLUTCH SPRINGS:	4x1.0
ENGINE POSITION:	Front <input checked="" type="checkbox"/> Rear <input type="checkbox"/>
BRAKE BIAS:	front 50 % rear 50 %

### Chassis Braces:

Center  Rear Left  Rear Right

### Front Outer (Sweep)

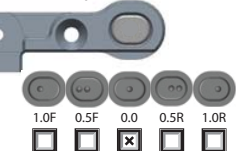

1.0F  0.5F  0.0  0.5R  1.0R

### Front Inner (Kick Up)



12.0°  11.5°  11.0°  10.5°  10.0°

### Rear End:

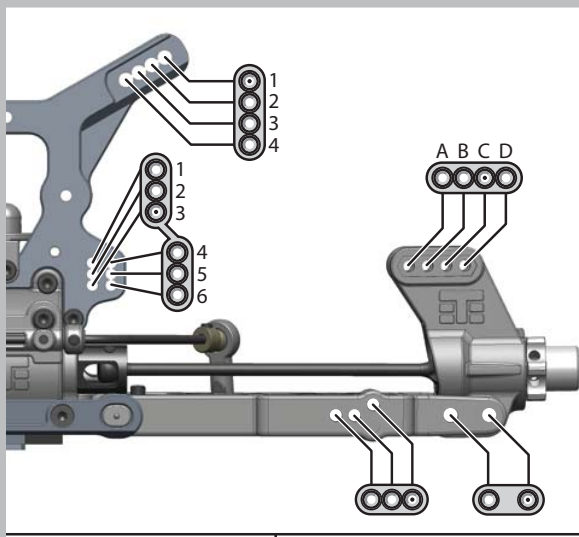

### Rear Outer (Toe In)

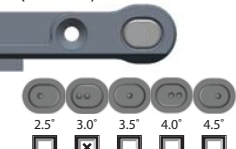

2.5°  3.0°  3.5°  4.0°  4.5°

### Rear Inner (Anti-Squat)

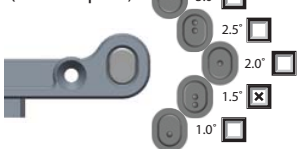

3.0°  2.5°  2.0°  1.5°  1.0°