



Name: _____ Date: _____ Event/Track: _____

Track Conditions: Outdoor Indoor Wet Dry High Bite Low Bite Rough
 Smooth Hard Packed Loose/Loamy Blue Groove

Bumpsteer/Ackerman/Servo Saver/Steering Stop:

 <p># washers <input type="checkbox"/> over <input type="checkbox"/> under ballstud <input type="checkbox"/> <input type="checkbox"/></p>	 <p># washers <input type="checkbox"/> over <input type="checkbox"/> under ballstud <input checked="" type="checkbox"/> <input type="checkbox"/></p>	 <p><input type="checkbox"/> front <input checked="" type="checkbox"/> middle <input type="checkbox"/> rear</p>
---	---	--

Front End:

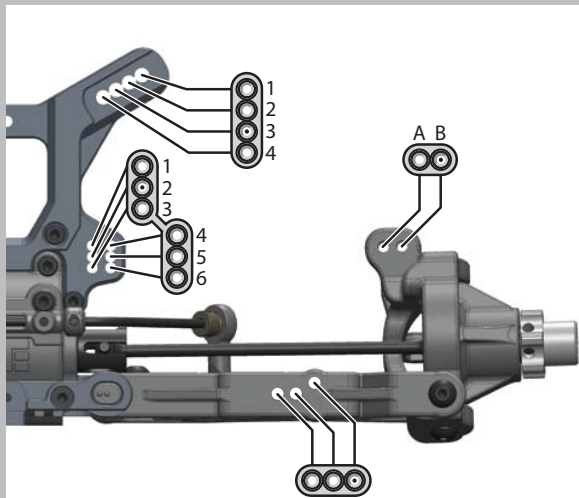

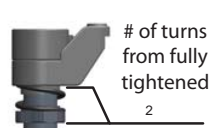
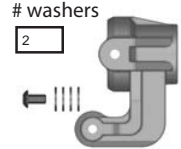
 <p># of turns from fully tightened 2</p>	 <p># washers <input type="checkbox"/> <input type="checkbox"/> <input type="checkbox"/></p>
---	---

Suspension:

	FRONT	REAR
RIDE HEIGHT:	27	28
TOE (in/out):	2	4
CAMBER:	-2	-2.5
CASTER:	10 Deg°	
SHOCK LENGTH (DROOP):	full	full
SWAY BAR:	2.6	2.5

NOTES: option caster block

Body/Wing:

BODY:	stock
WING:	stock

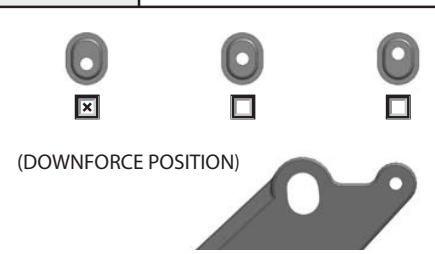

(DOWNFORCE POSITION)

Wheelbase:

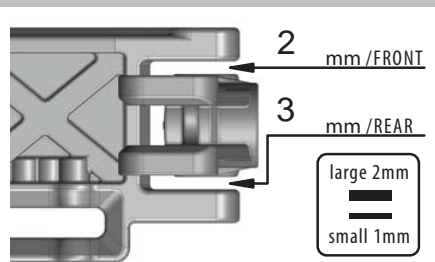

Notes:

LRC Block
 Losi Steel flywheel

	FRONT	REAR
STD/EMUL/VENT:	stock	stock
PISTON:	1.3 8H	1.3 8H
OIL:	500	350
BLADDER:	grey	grey
REBOUND:	90 %	90 %
SPRING:	pink	red

NOTES: PT racing oils

Tires / Wheels:

	FRONT	REAR
BRAND:	proline	proline
TREAD:	holeshots	holeshots
COMPOUND:	M4	M4
INSERT:	blue	blue
WHEEL:	V2	V2

NOTES:

Differential Oil:

FRONT	CENTER	REAR
7	7	4

NOTES: PT oils

Equipment:

ENGINE:	Fusion X3
PIPE:	9901
PLUG:	
FUEL:	Byrons Worlds
RX BATT:	Trakpower
SERVO:	steering / throttle/brake Hitec / Hitec

Drivetrain:

CLUTCH/SPUR:	13 / stock (teeth)
CLUTCH SHOES:	2 carbon/2AL
CLUTCH SPRINGS:	4-.9
ENGINE POSITION:	Front <input checked="" type="checkbox"/> Rear <input type="checkbox"/>
BRAKE BIAS:	front 80 % rear 20 %

Chassis Braces:

Center Rear Left Rear Right

Front Outer (Sweep)

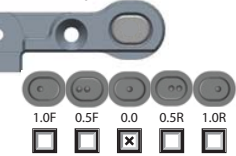

1.0F 0.5F 0.0 0.5R 1.0R

Front Inner (Kick Up)



12.0° 11.5° 11.0° 10.5° 10.0°

Rear End:

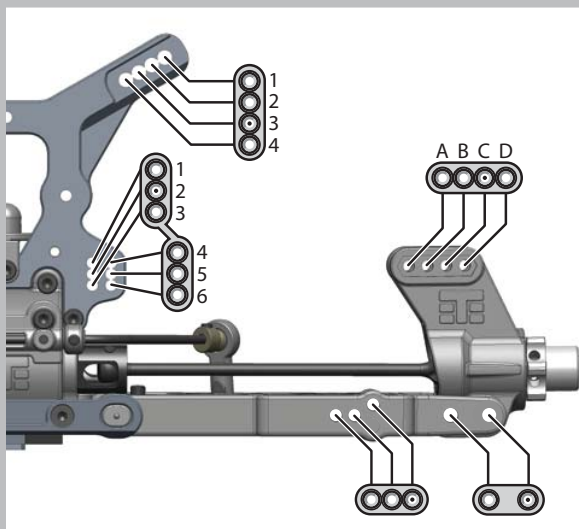

Rear Outer (Toe In)

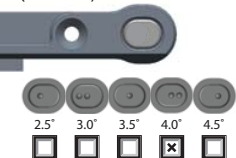

2.5° 3.0° 3.5° 4.0° 4.5°

Rear Inner (Anti-Squat)

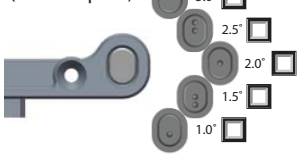

3.0° 2.5° 2.0° 1.5° 1.0°