



Name: MANEL PRADES Date: 08/11/2014 Event/Track: BARCELONA (MONTJUIC)

Track Conditions: Outdoor Indoor Wet Dry High Bite Low Bite Rough
 Smooth Hard Packed Loose/Loamy Blue Groove

Bumpsteer/Ackerman/Servo Saver/Steering Stop:

 <p># washers 2 over 2 under ballstud <input type="checkbox"/> <input checked="" type="checkbox"/></p>	 <p># washers 2 over 2 under ballstud <input checked="" type="checkbox"/> <input type="checkbox"/></p>	 <p><input type="checkbox"/> front <input type="checkbox"/> middle <input checked="" type="checkbox"/> rear</p>
--	---	--

Front End:

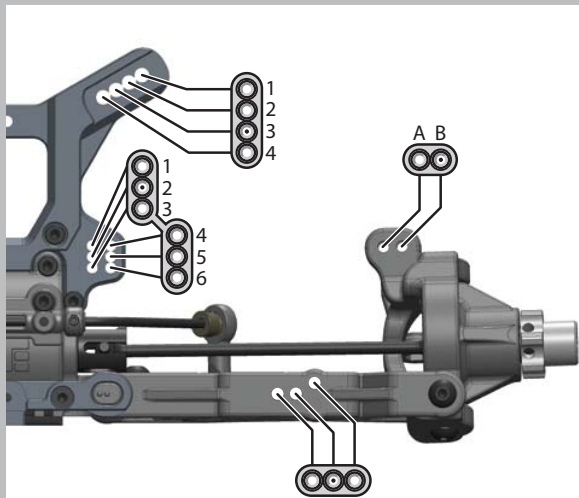

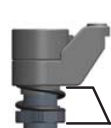
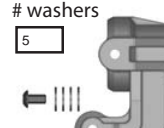
 <p># of turns from fully tightened 4</p>	 <p># washers 5</p>
--	---

Suspension:

	FRONT	REAR
RIDE HEIGHT:	22	23
TOE (in/out):		4°
CAMBER:	-2	-2
CASTER:	15 Deg°	
SHOCK LENGTH (DROOP):		
SWAY BAR:	2.4	2.8

NOTES:

Body/Wing:

BODY:	STOCK
WING:	STOCK

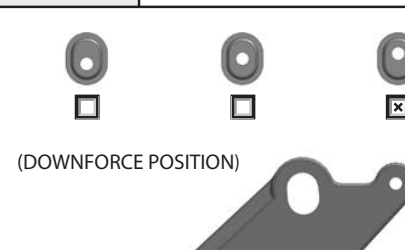

(DOWNFORCE POSITION)

Wheelbase:

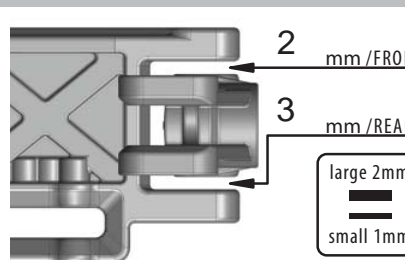

Notes:

Rear Outer :LRC +1
 Rear Inner : Special Plate

	FRONT	REAR
STD/EMUL/VENT:	VENT	VENT
PISTON:	8/1.3	8/1.3
OIL:	400	350
BLADDER:		
REBOUND:	5 %	5 %
SPRING:	YELLOW	RED

NOTES:

Tires / Wheels:

	FRONT	REAR
BRAND:		
TREAD:		
COMPOUND:		
INSERT:		
WHEEL:		

NOTES:

Differential Oil:

	FRONT	CENTER	REAR
	5	5	5

NOTES:

Equipment:

ENGINE:	OS
PIPE:	OS
PLUG:	OS P3
FUEL:	O'DONNELL
RX BATT:	RB 1500 (7.4)
SERVO:	steering / throttle/brake HIGHEST 1100 / HIGHEST 2100

Drivetrain:

CLUTCH/SPUR:	15 / 44 (teeth)
CLUTCH SHOES:	STOCK 7075
CLUTCH SPRINGS:	2 GREEN 2 GOLD
ENGINE POSITION:	Front <input checked="" type="checkbox"/> Rear <input type="checkbox"/>
BRAKE BIAS:	front 65 % rear 35 %

Chassis Braces:

Center Rear Left Rear Right

Front Outer (Sweep)



1.0F 0.5F 0.0 0.5R 1.0R

Front Inner (Kick Up)



12.0° 11.5° 11.0° 10.5° 10.0°

Rear End:

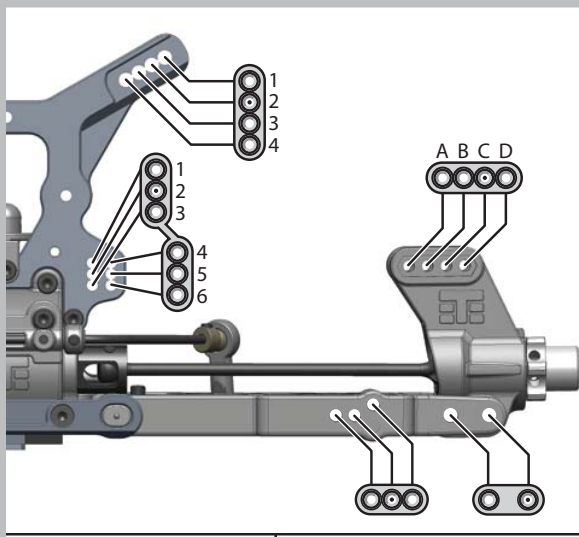

Rear Outer (Toe In)

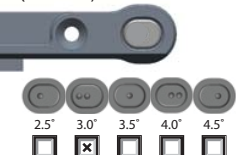

2.5° 3.0° 3.5° 4.0° 4.5°

Rear Inner (Anti-Squat)

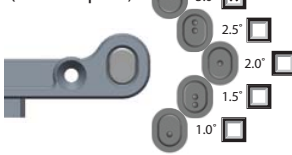

3.0° 2.5° 2.0° 1.5° 1.0°