



Name: Darren Lord Date: 20th July 2014 Event/Track: Australian nitro titles Meakin park

Track Conditions: Outdoor Indoor Wet Dry High Bite Low Bite Rough
 Smooth Hard Packed Loose/Loamy Blue Groove

Bumpsteer/Ackerman/Servo Saver/Steering Stop:

 <p># washers 4 over under ballstud <input type="checkbox"/> <input checked="" type="checkbox"/></p>	 <p># washers 4 over under ballstud <input checked="" type="checkbox"/> <input type="checkbox"/></p>	 <p><input type="checkbox"/> front <input checked="" type="checkbox"/> middle <input type="checkbox"/> rear</p>
------------------------------------------------------------------------------------------------------------------------------------------------------------------------------------------------------	-------------------------------------------------------------------------------------------------------------------------------------------------------------------------------------------------------	----------------------------------------------------------------------------------------------------------------------------------------------------------------------------------------------------------

Front End:

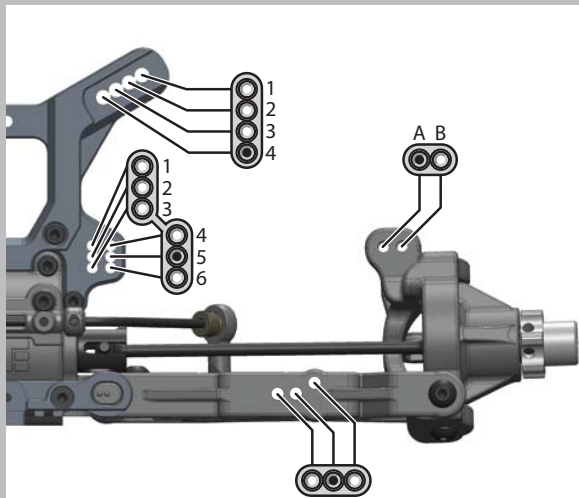

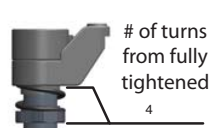
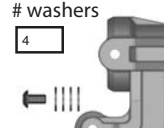
 <p># of turns from fully tightened 4</p>	 <p># washers 4</p>
--------------------------------------------------------------------------------------------------------------------------------	-----------------------------------------------------------------------------------------------------------

Suspension:

	FRONT	REAR
RIDE HEIGHT:	27	28
TOE (in/out):	1.5 out	4 in
CAMBER:	2	2
CASTER:	15 Deg°	
SHOCK LENGTH (DROOP):	104	120
SWAY BAR:	2.6	2.5

NOTES:

Body/Wing:

BODY:	FTW
WING:	Stock

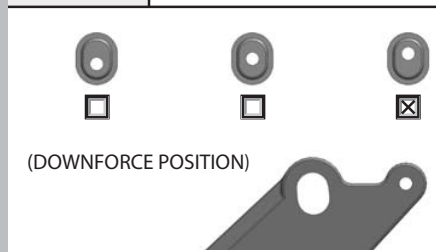

(DOWNFORCE POSITION)

Wheelbase:

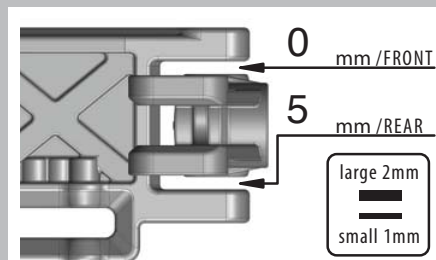

Notes:

Clutch set up light as I prefer smooth electric type driving

	FRONT	REAR
STD/EMUL/VENT:	Emul	Emul
PISTON:	Fioroni	Fioroni
OIL:	40	35
BLADDER:	No	No
REBOUND:	5 %	5 %
SPRING:	Pink	Red

NOTES:

Tires / Wheels:

	FRONT	REAR
BRAND:	Panther	Panther
TREAD:	Gator	Gator
COMPOUND:	Super soft	Super soft
INSERT:	Closed cell	Closed cell
WHEEL:	De racing	De racing

NOTES: Locktight 406 glue

Differential Oil:

	FRONT	CENTER	REAR
	7	7	3

NOTES:

Equipment:

ENGINE:	Picco Team Spec
PIPE:	Picco 2099
PLUG:	P3
FUEL:	Podified 25%
RX BATT:	Smc 2000
SERVO:	steering / throttle/brake Kopropo / Kopropo

Drivetrain:

CLUTCH/SPUR:	15 / 44 (teeth)
CLUTCH SHOES:	Stock
CLUTCH SPRINGS:	4 x 0.9
ENGINE POSITION:	Front <input checked="" type="checkbox"/> Rear <input type="checkbox"/>
BRAKE BIAS:	front % rear % 60 % 40 %

Chassis Braces:

Center Rear Left Rear Right

Front Outer (Sweep)



1.0F 0.5F 0.0 0.5R 1.0R

Front Inner (Kick Up)



12.0°
11.5°
11.0°
10.5°
10.0°

Rear End:

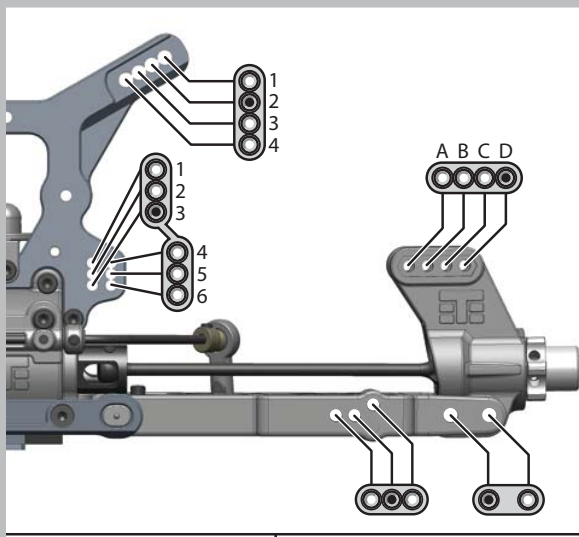

Rear Outer (Toe In)

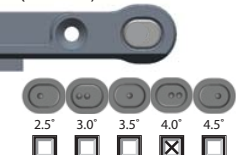

2.5° 3.0° 3.5° 4.0° 4.5°

Rear Inner (Anti-Squat)

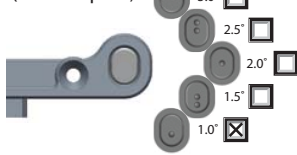

3.0°
2.5°
2.0°
1.5°
1.0°