



Name: Matt Wolter

Date: 12/15/13

Event/Track: CVRC Toys for Tots

Track Conditions: Outdoor Indoor Wet Dry High Bite Low Bite Rough
 Smooth Hard Packed Loose/Loamy Blue Groove

Bumpsteer/Ackerman/Servo Saver/Steering Stop:

 <p># washers 4 over 0 under ballstud <input type="checkbox"/> <input checked="" type="checkbox"/></p>	 <p># washers 1 over 0 under ballstud <input checked="" type="checkbox"/> <input type="checkbox"/></p>	 <p><input checked="" type="checkbox"/> front <input type="checkbox"/> middle <input type="checkbox"/> rear</p>
---	--	--

Front End:

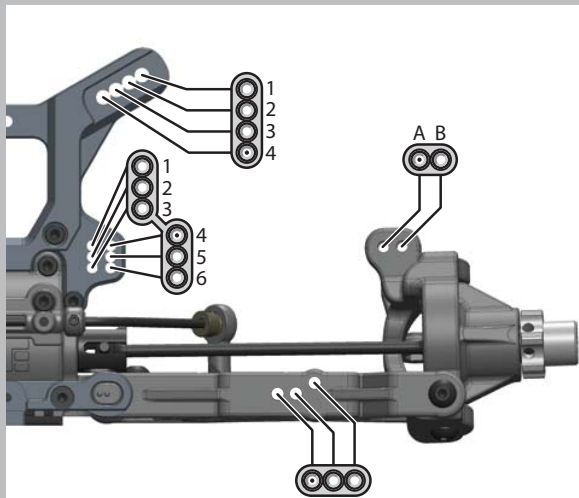

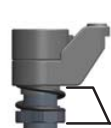
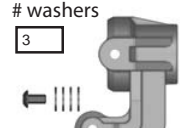
 <p># of turns from fully tightened 4</p>	 <p># washers 3</p>
--	---

Suspension:

	FRONT	REAR
RIDE HEIGHT:	26	25
TOE (in/out):	-2	
CAMBER:	-2.5	-3
CASTER:	15 Deg°	
SHOCK LENGTH (DROOP):	104	116
SWAY BAR:	2.8	2.6

NOTES:

Body/Wing:

BODY:	Tekno
WING:	Tekno

(DOWNFORCE POSITION)

Wheelbase:

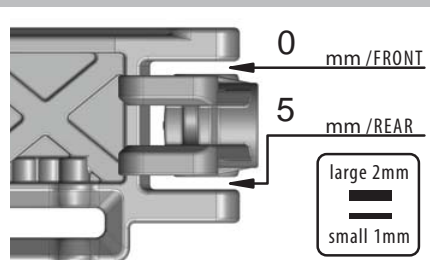

Notes:

Reversed screws in spindle steering link so the threads wont hit the arms

	FRONT	REAR
STD/EMUL/VENT:	STD	STD
PISTON:	8x1.3	8x1.3
OIL:	500	400
BLADDER:	Y	Y
REBOUND:	10 %	10 %
SPRING:	Yellow	Red

NOTES: New non vented caps

Tires / Wheels:

	FRONT	REAR
BRAND:	Pro	
TREAD:	Blockades	
COMPOUND:	M3	
INSERT:	Blue	
WHEEL:	Pro v1	

NOTES:

Differential Oil:

	FRONT	CENTER	REAR
	8	7	6

NOTES:

Equipment:

ENGINE:	JQ The Engine
PIPE:	Werks 2058
PLUG:	OS P3
FUEL:	Byrons 30/8
RX BATT:	Protek 2600 Hump
SERVO:	steering / throttle/brake KO Power / KO Power

Drivetrain:

CLUTCH/SPUR:	15 / (teeth)
CLUTCH SHOES:	Alum
CLUTCH SPRINGS:	2 Green 2 Gold
ENGINE POSITION:	Front <input checked="" type="checkbox"/> Rear <input type="checkbox"/>
BRAKE BIAS:	front 40 % rear 60 %

Chassis Braces:

Center Rear Left Rear Right

Front Outer (Sweep)

1.0F 0.5F 0.0 0.5R 1.0R

Front Inner (Kick Up)

12.0 11.5 11.0 10.5 10.0

Rear End:

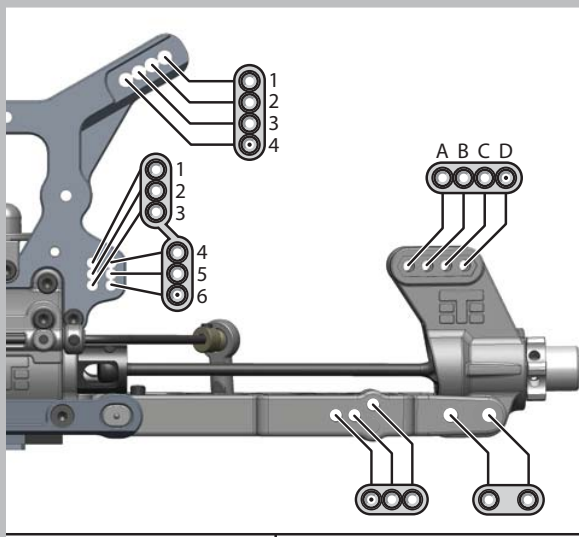

Rear Outer (Toe In)

2.5 3.0 3.5 4.0 4.5

Rear Inner (Anti-Squat)

3.0 2.5 2.0 1.5 1.0