

Name: shaun kirkman Date: 2016/2017 Event: good all around setup

Track: Indoor Outdoor Size: Small Medium Large Traction: Low Med High

Surface: Smooth Bumpy Rutted Type: Loose/Loamy Hard Pack Blue Groove Clay

Bumpsteer/Ackerman/Servo Saver/Steering Stop: Condition: Dusty Dry Wet Muddy

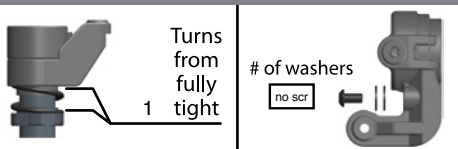
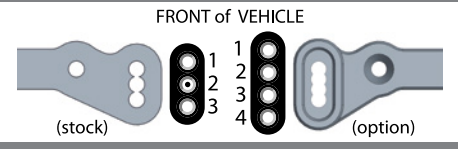
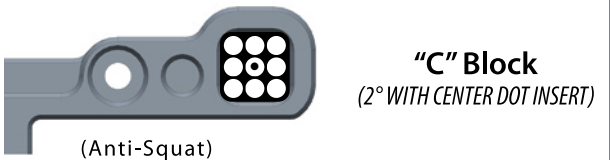
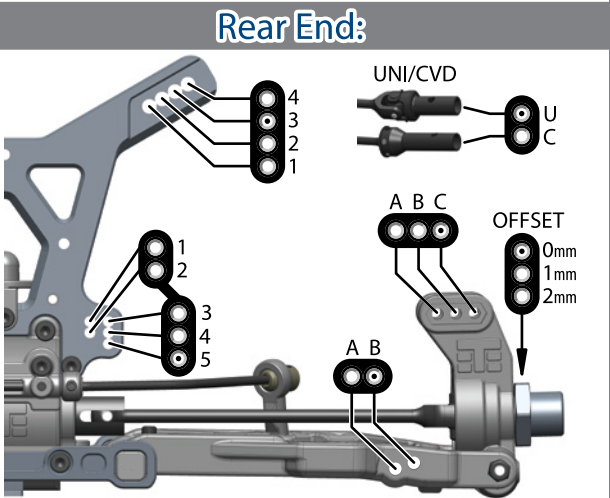
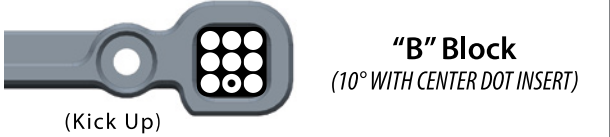
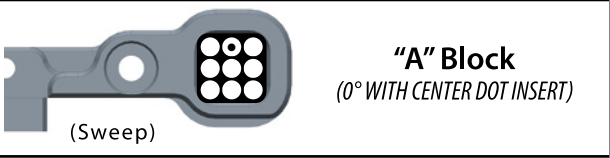
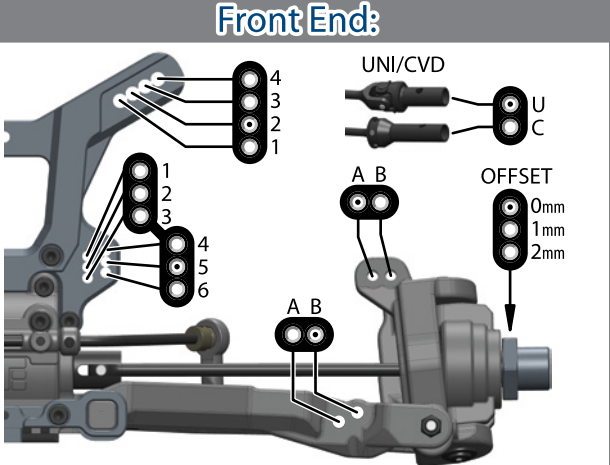

Suspension:		
	FRONT	REAR
RIDE HEIGHT	24	29
CAMBER	-2	-2
CASTER		
SWEEP		
KICK UP	2	
ANTI-SQUAT		2
TOE (in/out)	2 out	3
SWAY BAR	2.4	2.4
SHOCK LENGTH (DROOP)	119	136

Body/Wing:	
BODY MAKE	stock
WING MAKE	tiki4 kyosho/clear lexan PL

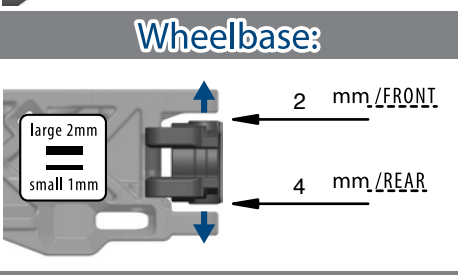
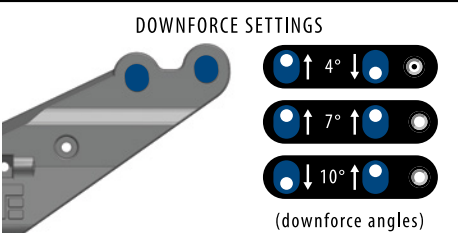
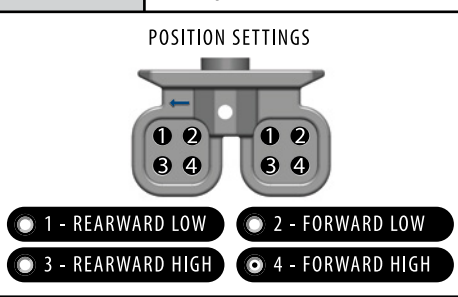

Shocks:		
	FRONT	REAR
OIL/ BRAND:	37.5	30 or 32.5
PISTON	3x2.1 taper down	3x2.0 flat
SPRING	black	orange
REBOUND	min %	min %
STD/EMUL/VENT	emul	emul
NOTES:	lost oils. sometimes yellow rear springs if super bumpy	

Tires/Wheels:		
	FRONT	REAR
BRAND/TREAD		
COMPOUND		
INSERT		
WHEEL		
NOTES:	Pro-Line	

Differential Oil:			
	FRONT	CENTER	REAR
	7	7	5

Equipment:	
ENGINE/ PIPE:	O.S spec 2 gold ed. / O.S 2060
FUEL/ PLUG:	sidewinder blue 30% / os p3
RX BATT:	protek 2200
SERVO:	(steering) hitec9370hs / (throttle/brake) hitec9370hs

Drivetrain:	
CLUTCH/SPUR:	13 / 48 (teeth)
CLUTCH SHOES:	aluminum
CLUTCH SPRINGS:	2 green 2 gold
BRAKE BIAS:	(front) 40 % / (rear) 60 %

Chassis Braces:	
Center Diff	<input type="radio"/> Left Rear <input type="radio"/> R Rear Short <input checked="" type="radio"/> R Rear Long <input type="radio"/>
(front brace is always used)	

Notes: