

Name: Ryan Lutz

Date: 12-5-15

Event: U.A.E. National Day

Track: Indoor Outdoor Size: Small Medium Large Traction: Low Med High

Surface: Smooth Bumpy Rutted Type: Loose/Loamy Hard Pack Blue Groove Clay

Bumpsteer/Ackerman/Servo Saver/Steering Stop:

Condition: Dusty Dry Wet Muddy

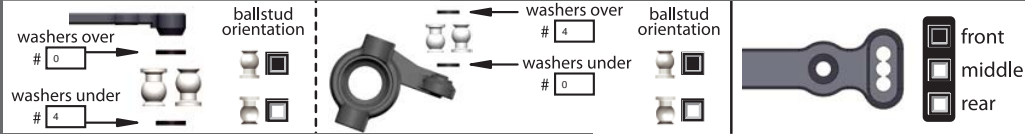

Front End:

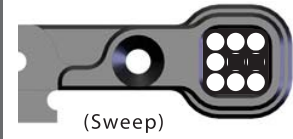
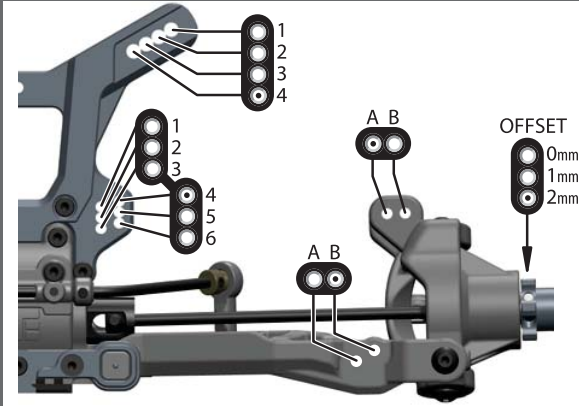

"A" Block
(0° WITH CENTER DOT INSERT)

(Sweep)



"B" Block
(10° WITH CENTER DOT INSERT)

(Kick Up)

Rear End:

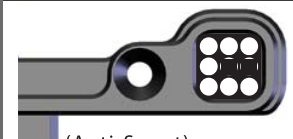
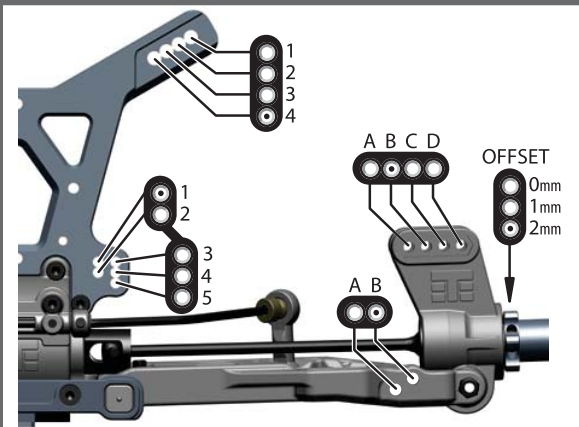

"C" Block
(2° WITH CENTER DOT INSERT)

(Anti-Squat)



"D" Block
(3° WITH CENTER DOT INSERT)

(Rear Toe)

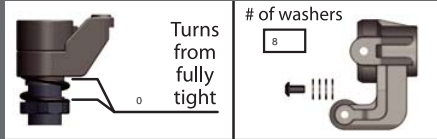

Suspension:

	FRONT	REAR
RIDE HEIGHT	26	26
CAMBER	-3	-3
CASTER	15* Trailin ⁺	
SWEEP	0	
KICK UP	11*	
ANTI-SQUAT		3*
TOE (in/out)	1* in	3*
SWAY BAR	2.4	2.3
SHOCK LENGTH (DROOP)	117.5	133

Body/Wing:

BODY MAKE	LFR Assassin
WING MAKE	Tekno Cut w/ holes

POSITION SETTINGS

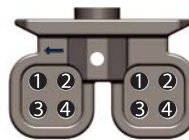

- 1 - REARWARD LOW
- 2 - FOREWARD LOW
- 3 - REARWARD HIGH
- 4 - FOREWARD HIGH

DOWNFORCE SETTINGS

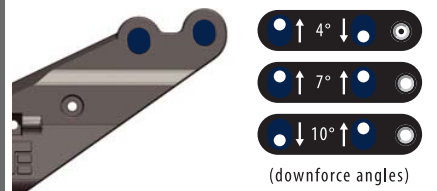

Wheelbase:

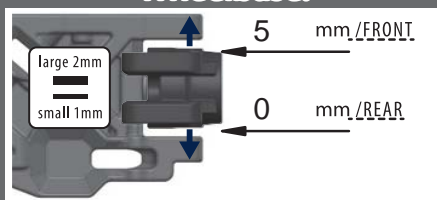

Shocks:

	FRONT	REAR
OIL	375	425
BRAND	PTRC	PTRC
PISTON	4x1.8	4x1.8
SPRING	Pink	Red
REBOUND	20 %	20 %
STD/EMUL/VENT	Vent	Vent

NOTES:

Tires/Wheels:

	FRONT	REAR
BRAND/TREAD	AKA	Chainlink
COMPOUND	L.W. Med	L.W. Med
INSERT	AKA Red	AKA Red
WHEEL	AKA Evo	AKA Evo

NOTES: Concrete Surface

Differential Oil:

	FRONT	CENTER	REAR
	30K	25K	20K

Equipment:

ENGINE/PIPE:	Dragon 3 / 2130A
PLUG:	LutzRC L4
FUEL:	Byrons 30/11
RX BATT:	ProTek Lipo 2600
SERVOS:	(steering) S9353HV / (throttle/brake) S9353HV

Drivetrain:

CLUTCH/SPUR:	15t / 46t (teeth)
CLUTCH SHOES:	4 x Alum
CLUTCH SPRINGS:	3 x 1.0, 1 x 1.1
BRAKE BIAS:	(front) 60 % / (rear) 40 %

Chassis Braces:

Center <input type="checkbox"/> Left Rear <input type="checkbox"/> Right Rear <input type="checkbox"/>
(front brace is always recommended)

Notes:

Concrete Crazy high traction!