

Name: Joe Bornhorst

Date: 12/2/15

Event: US Open at Fear Farm

Track: Indoor Outdoor **Size:** Small Medium Large **Traction:** Low Med High

Surface: Smooth Bumpy Rutted **Type:** Loose/Loamy Hard Pack Blue Groove Clay

Bumpsteer/Ackerman/Servo Saver/Steering Stop:

Condition: Dusty Dry Wet Muddy

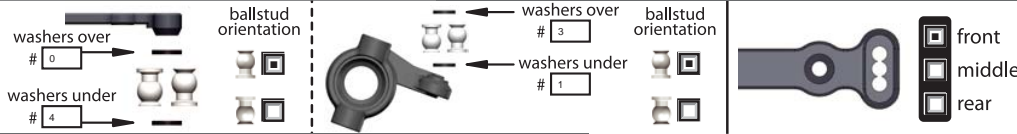

Front End:

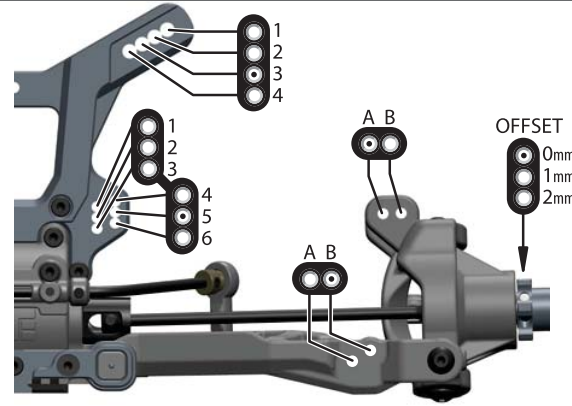

Rear End:

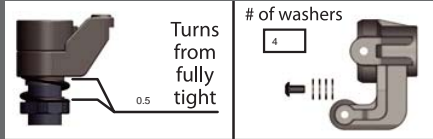
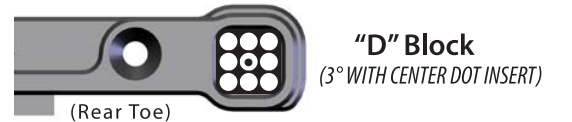
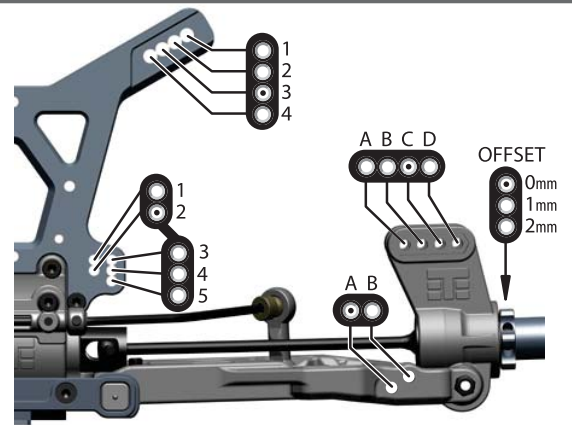

Suspension:

	FRONT	REAR
RIDE HEIGHT	27	29
CAMBER	-2.5	-2
CASTER	15 trailing	
SWEEP		
KICK UP		
ANTI-SQUAT		
TOE (in/out)	1 out	
SWAY BAR	2.3	2.4
SHOCK LENGTH (DROOP)	121	136

Body/Wing:

BODY MAKE	LFR
WING MAKE	Tekno

POSITION SETTINGS

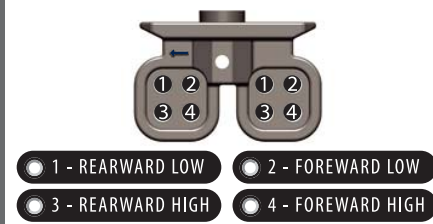

DOWNFORCE SETTINGS

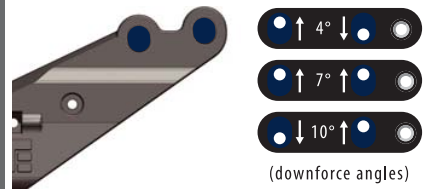

Wheelbase:

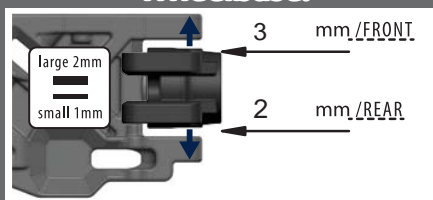

Shocks:

	FRONT	REAR
OIL	700	750
BRAND	PT	PT
PISTON	3x2.1	3x2.1
SPRING	Pink	Red
REBOUND	min %	min %
STD/EMUL/VENT	vent	vent

NOTES:

Tires/Wheels:

	FRONT	REAR
BRAND/TREAD	AKA Impact	AKA Impact
COMPOUND	Soft Long Wear	Soft Long Wear
INSERT	Red	Red
WHEEL	Evo	Evo

NOTES:

Differential Oil:

	FRONT	CENTER	REAR
	12	12	10

Equipment:

ENGINE/PIPE:	OS B2101 / OS 2090
PLUG:	OS P3
FUEL:	Byrons 30-8
RX BATT:	SMC
SERVOS:	(steering) Highest / (throttle/brake) Highest

Drivetrain:

CLUTCH/SPUR:	15 / 46 (teeth)
CLUTCH SHOES:	Buku composite
CLUTCH SPRINGS:	0:1, 1:3, 2:4
BRAKE BIAS:	(front) 60 % / (rear) 40 %

Chassis Braces:

Center <input type="checkbox"/> Left Rear <input type="checkbox"/> Right Rear <input type="checkbox"/>
(front brace is always recommended)

Notes:

Clutch springs = "Spring number : turns from flush"