

Name: Ryan Lutz

Date: 11-22-15

Event: U.S. Open Fear Farm

Track: Indoor Outdoor **Size:** Small Medium Large **Traction:** Low Med High

Surface: Smooth Bumpy Rutted **Type:** Loose/Loamy Hard Pack Blue Groove Clay

Bumpsteer/Ackerman/Servo Saver/Steering Stop:

Condition: Dusty Dry Wet Muddy



Front End:

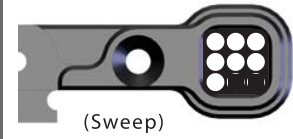
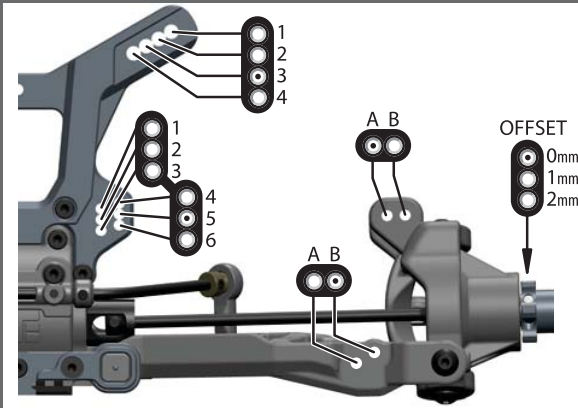

"A" Block
(0° WITH CENTER DOT INSERT)

(Sweep)



"B" Block
(10° WITH CENTER DOT INSERT)

(Kick Up)

Rear End:

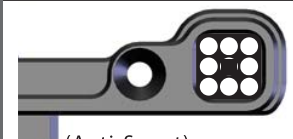
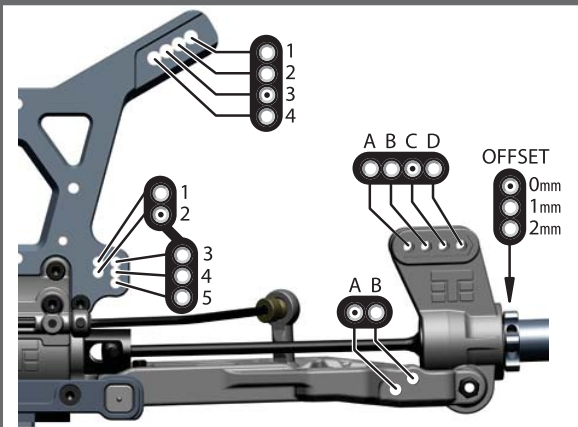

"C" Block
(2° WITH CENTER DOT INSERT)

(Anti-Squat)



"D" Block
(3° WITH CENTER DOT INSERT)

(Rear Toe)

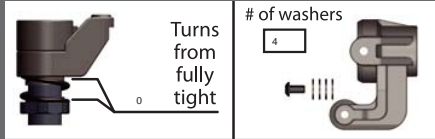

Suspension:

	FRONT	REAR
RIDE HEIGHT	27	29
CAMBER	-2	-2
CASTER	15*	
SWEEP	1* Out	
KICK UP	8*	
ANTI-SQUAT		2*
TOE (in/out)	2* Out	3*
SWAY BAR	2.3	2.4
SHOCK LENGTH (DROOP)	119.5	134.5

Body/Wing:

BODY MAKE	LFR Assassin
WING MAKE	Tekno Cut w/ Holes

POSITION SETTINGS

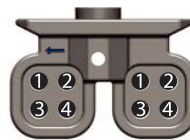

- 1 - REARWARD LOW
- 2 - FOREWARD LOW
- 3 - REARWARD HIGH
- 4 - FOREWARD HIGH

DOWNFORCE SETTINGS

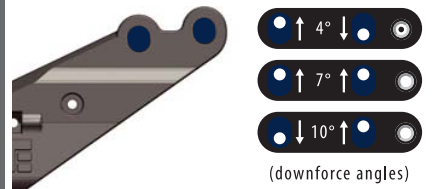

Wheelbase:

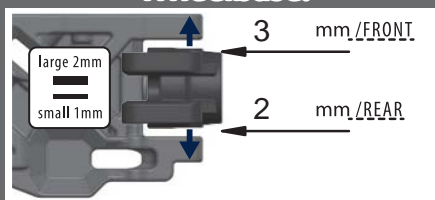

Shocks:

	FRONT	REAR
OIL	650	725
BRAND	PTRC	PTRC
PISTON	3 x 2.1	3 x 2.1
SPRING	Pink	Red
REBOUND	20 %	20 %
STD/EMUL/VENT	Vent	Vent

NOTES:

Tires/Wheels:

	FRONT	REAR
BRAND/TREAD	Impact	Impact
COMPOUND	Soft L.W.	Soft L.W.
INSERT	AKA Red	AKA Red
WHEEL	AKA Evo	AKA Evo

NOTES:

Differential Oil:

	FRONT	CENTER	REAR
12K	15K	10K	

Equipment:

ENGINE/PIPE:	Dragon 3 / 2130A
PLUG:	LutzRC L4
FUEL:	Byrons 30/8
RX BATT:	ProTek 2600
SERVOs:	(steering) Futaba / (throttle/brake) S9353HV

Drivetrain:

CLUTCH/SPUR:	15t / 46t (teeth)
CLUTCH SHOES:	4 x Alum
CLUTCH SPRINGS:	1x1.1, 3x1.0
BRAKE BIAS:	(front) 55 % / (rear) 45 %

Chassis Braces:

Center Left Rear Right Rear
(front brace is always recommended)

Notes: