

**Name:** Ryan Lutz

**Date:** 11-15-15

**Event:** Gas Champs Dialed In

**Track:** Indoor  Outdoor  **Size:** Small  Medium  Large  **Traction:** Low  Med  High

**Surface:** Smooth  Bumpy  Rutted  **Type:** Loose/Loamy  Hard Pack  Blue Groove  Clay

**Bumpsteer/Ackerman/Servo Saver/Steering Stop:**

**Condition:** Dusty  Dry  Wet  Muddy

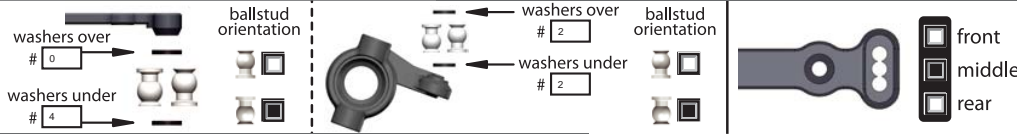

### Front End:

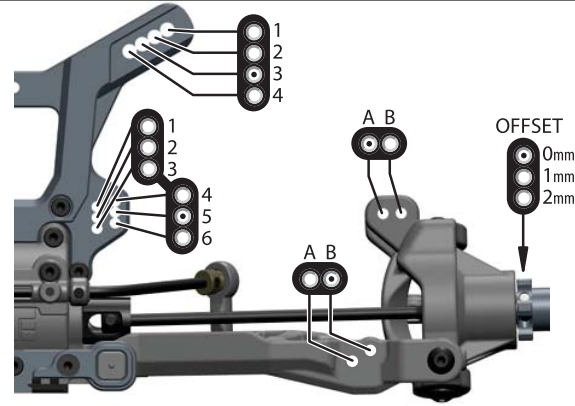

### Rear End:

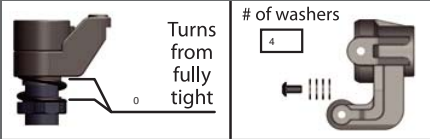
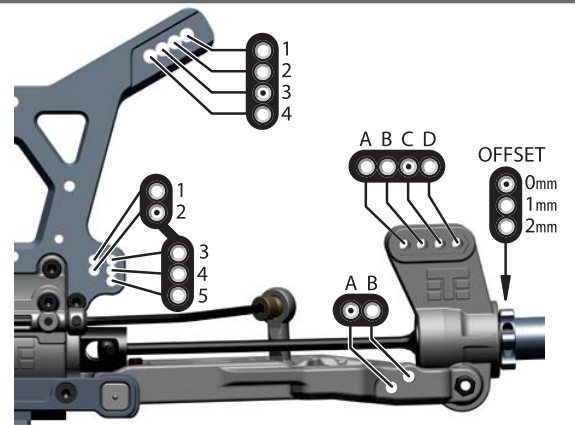

### Suspension:

	FRONT	REAR
RIDE HEIGHT	27	27
CAMBER	-2	-3
CASTER	15* Trail.	
SWEEP	0*	
KICK UP	8*	
ANTI-SQUAT		2*
TOE (in/out)	0	3.5*
SWAY BAR	2.3	2.4
SHOCK LENGTH (DROOP)	119	133

### Body/Wing:

BODY MAKE	LFR Assassin
WING MAKE	Stock Tekno Cut

#### POSITION SETTINGS

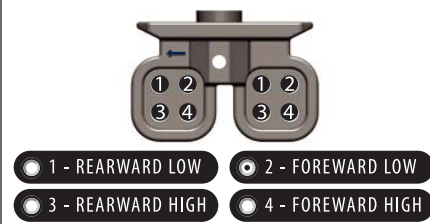

#### DOWNFORCE SETTINGS

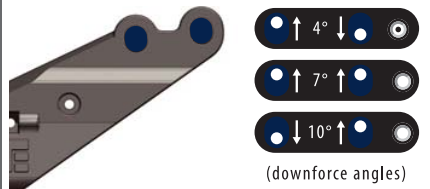

### Wheelbase:

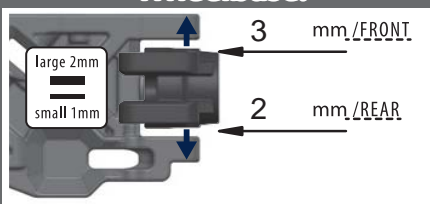

### Shocks:

	FRONT	REAR
OIL	650	700
BRAND	PTRC	PTRC
PISTON	3x2.1	3x2.1
SPRING	Pink	Orange
REBOUND	10 %	10 %
STD/EMUL/VENT	Vent	Vent

NOTES:

### Tires/Wheels:

	FRONT	REAR
BRAND/TREAD	AKA	Impact
COMPOUND	L.W. Soft	L.W. Soft
INSERT	AKA Red	AKA Red
WHEEL	AKA Evo	AKA Evo

NOTES:

### Differential Oil:

	FRONT	CENTER	REAR
9K	9K	8K	

### Equipment:

ENGINE/PIPE:	Dragon 3 / 2130 Alph
PLUG:	LutzRC L4
FUEL:	Byrons 30/8
RX BATT:	ProTek 2600 Lipo
SERVOS:	(steering) S9353HV / (throttle/brake) S9353HV

### Drivetrain:

CLUTCH/SPUR:	15t / 46t (teeth)
CLUTCH SHOES:	4 x Alum
CLUTCH SPRINGS:	3 x 1.0, 1 x 1.1
BRAKE BIAS:	(front) 55 % / (rear) 45 %

### Chassis Braces:

Center <input type="checkbox"/> Left Rear <input type="checkbox"/> Right Rear <input type="checkbox"/>
(front brace is always recommended)

### Notes:

Track was catchy, edgy, dry