

Name: Juan Carlos Canas

Date: 22/08/2015

Event: Alhaurin

Track: Indoor Outdoor **Size:** Small Medium Large **Traction:** Low Med High

Surface: Smooth Bumpy Rutted **Type:** Loose/Loamy Hard Pack Blue Groove Clay

Bumpsteer/Ackerman/Servo Saver/Steering Stop:

Condition: Dusty Dry Wet Muddy

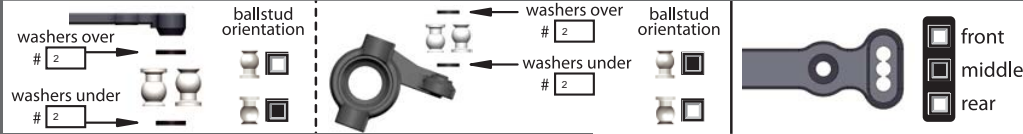

Front End:

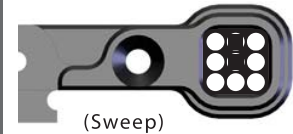
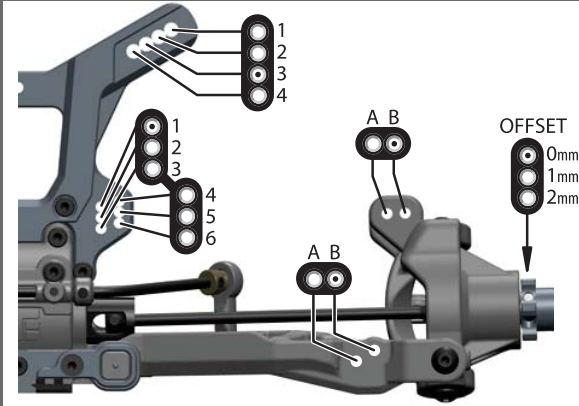

"A" Block
(0° WITH CENTER DOT INSERT)



"B" Block
(10° WITH CENTER DOT INSERT)

Rear End:

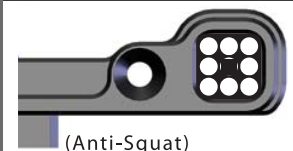
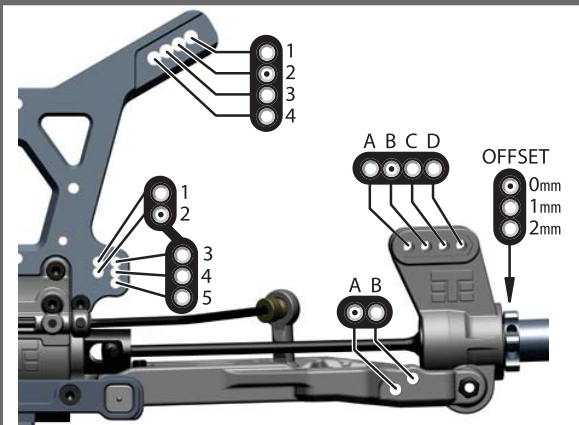

"C" Block
(2° WITH CENTER DOT INSERT)



"D" Block
(3° WITH CENTER DOT INSERT)

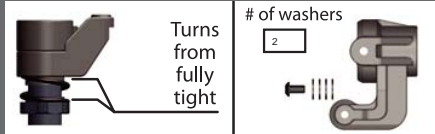

Suspension:

| | FRONT | REAR |
|----------------------|-------|------|
| RIDE HEIGHT | 24 | 27 |
| CAMBER | -3 | -4 |
| CASTER | 15 | |
| SWEEP | | |
| KICK UP | | |
| ANTI-SQUAT | | 2 |
| TOE (in/out) | | 4 |
| SWAY BAR | 2.4 | 2.4 |
| SHOCK LENGTH (DROOP) | 119 | 135 |

Body/Wing:

| | |
|-----------|----------|
| BODY MAKE | Tekno RC |
| WING MAKE | Tekno RC |

POSITION SETTINGS

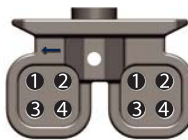

- 1 - REARWARD LOW
- 2 - FOREWARD LOW
- 3 - REARWARD HIGH
- 4 - FOREWARD HIGH

DOWNFORCE SETTINGS

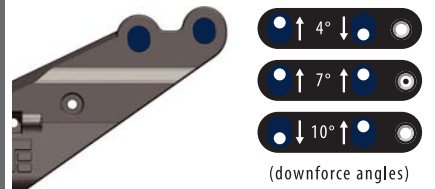

Wheelbase:

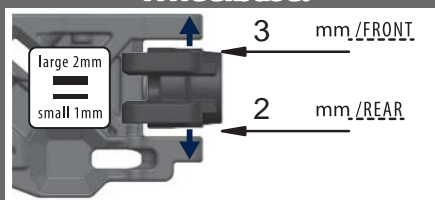

Shocks:

| | FRONT | REAR |
|---------------|-------|-------|
| OIL | 37.5 | 45 |
| BRAND | TLR | TLR |
| PISTON | 4X1.8 | 4X1.8 |
| SPRING | Black | Red |
| REBOUND | 25 % | 25 % |
| STD/EMUL/VENT | Vent | Vent |

NOTES:

Tires/Wheels:

| | FRONT | REAR |
|-------------|---------|---------|
| BRAND/TREAD | Impact | Impact |
| COMPOUND | Soft | Soft |
| INSERT | Red | Red |
| WHEEL | AKA Evo | AKA Evo |

NOTES:

Differential Oil:

| | FRONT | CENTER | REAR |
|--|-------|--------|------|
| | 7 | 5 | 5 |

Equipment:

| | |
|--------------|---|
| ENGINE/PIPE: | Picco / Picco |
| PLUG: | Picco T5 |
| FUEL: | O'Donnell |
| RX BATT: | Lipo 2500 |
| SERVOS: | (steering) Highest 24 / (throttle/brake) Highest 24 |

Drivetrain:

| | |
|-----------------|----------------------------|
| CLUTCH/SPUR: | 15 / 46 (teeth) |
| CLUTCH SHOES: | Tekno RC Aluminum |
| CLUTCH SPRINGS: | 2 Gold/2 Green |
| BRAKE BIAS: | (front) 60 % / (rear) 40 % |

Chassis Braces:

| |
|--|
| Center <input type="checkbox"/> Left Rear <input type="checkbox"/> Right Rear <input type="checkbox"/> |
| (front brace is always recommended) |

Notes: