

Name: Joe Bornhorst

Date: 8/16/15

Event: Wicked Weekend

Track: Indoor Outdoor **Size:** Small Medium Large **Traction:** Low Med High

Surface: Smooth Bumpy Rutted **Type:** Loose/Loamy Hard Pack Blue Groove Clay

Bumpsteer/Ackerman/Servo Saver/Steering Stop:

Condition: Dusty Dry Wet Muddy

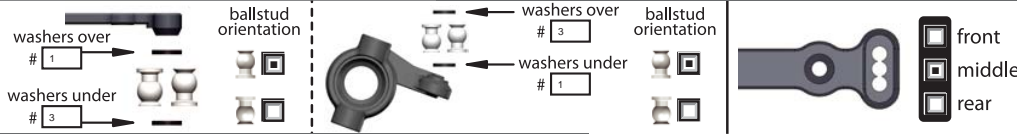

Front End:

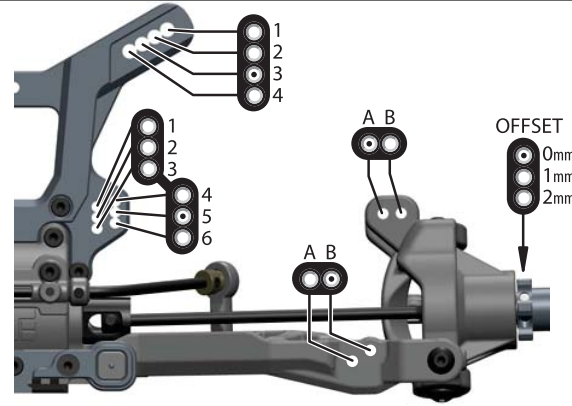

"A" Block
(0° WITH CENTER DOT INSERT)



"B" Block
(10° WITH CENTER DOT INSERT)

Rear End:

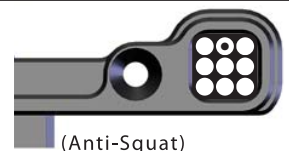
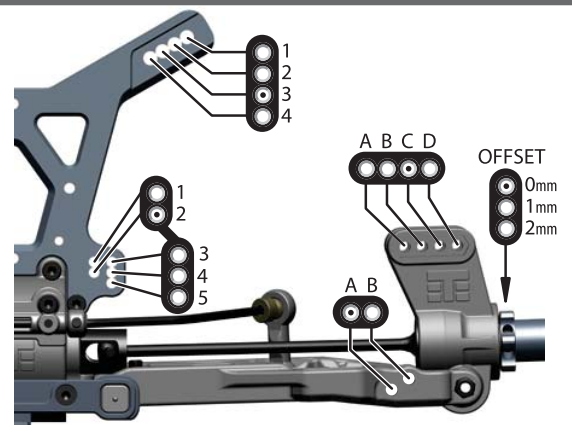

"C" Block
(2° WITH CENTER DOT INSERT)



"D" Block
(3° WITH CENTER DOT INSERT)

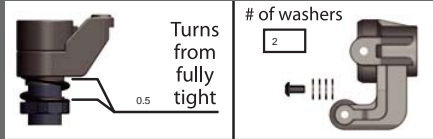

Suspension:

	FRONT	REAR
RIDE HEIGHT	27	27
CAMBER	-2.5	-3
CASTER	15 trail	
SWEEP		
KICK UP		
ANTI-SQUAT		
TOE (in/out)	heads up	
SWAY BAR	2.4	2.4
SHOCK LENGTH (DROOP)	121	136

Body/Wing:

BODY MAKE	LFR Assassin
WING MAKE	Tekno

POSITION SETTINGS

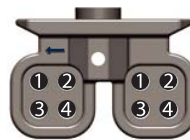

- 1 - REARWARD LOW
- 2 - FOREWARD LOW
- 3 - REARWARD HIGH
- 4 - FOREWARD HIGH

DOWNFORCE SETTINGS

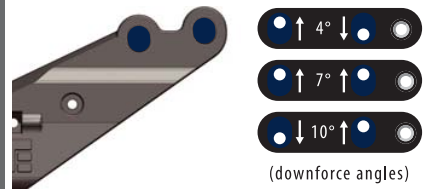

Wheelbase:

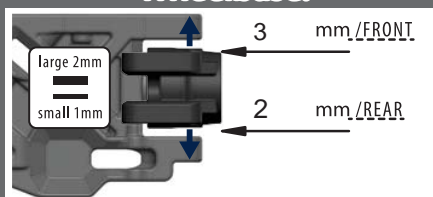

Shocks:

	FRONT	REAR
OIL	425	475
BRAND	PT	PT
PISTON	4x1.8	4x1.8
SPRING	Pink	Red
REBOUND	min %	min %
STD/EMUL/VENT	vent	vent

NOTES:

Tires/Wheels:

	FRONT	REAR
BRAND/TREAD	AKA	AKA
COMPOUND	Soft	Soft
INSERT	Red	Red
WHEEL	Evo	Evo

NOTES:

Differential Oil:

	FRONT	CENTER	REAR
	7k	7k	5k

Equipment:

ENGINE/PIPE:	O.S. B2101 / O.S. 2090
PLUG:	O.S. P3
FUEL:	Byron's 30-8
RX BATT:	SMC
SERVOS:	(steering) Highest / (throttle/brake) Highest

Drivetrain:

CLUTCH/SPUR:	15 / 44 (teeth)
CLUTCH SHOES:	Buku
CLUTCH SPRINGS:	Buku
BRAKE BIAS:	(front) 60 % / (rear) 40 %

Chassis Braces:

Center <input type="checkbox"/> Left Rear <input type="checkbox"/> Right Rear <input type="checkbox"/>
(front brace is always recommended)

Notes: