

Name: Billy Fischer **Date:** 7/26/2015 **Event:** Dash for Cash (Dialed In R)

Track: Indoor Outdoor **Size:** Small Medium Large **Traction:** Low Med High

Surface: Smooth Bumpy Rutted **Type:** Loose/Loamy Hard Pack Blue Groove Clay

Bumpsteer/Ackerman/Servo Saver/Steering Stop: **Condition:** Dusty Dry Wet Muddy

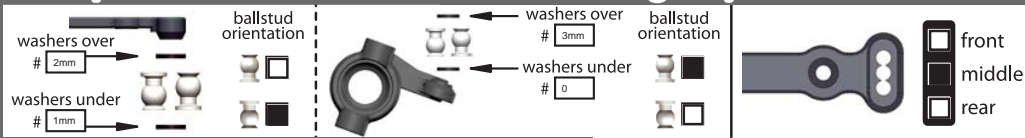

Front End:

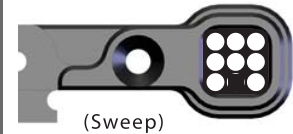
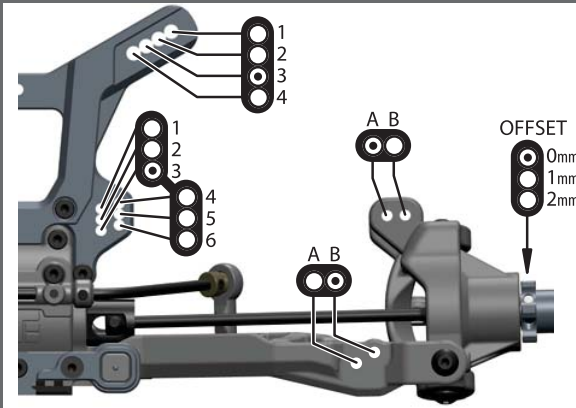

"A" Block
(0° WITH CENTER DOT INSERT)

(Sweep)



"B" Block
(10° WITH CENTER DOT INSERT)

(Kick Up)

Rear End:

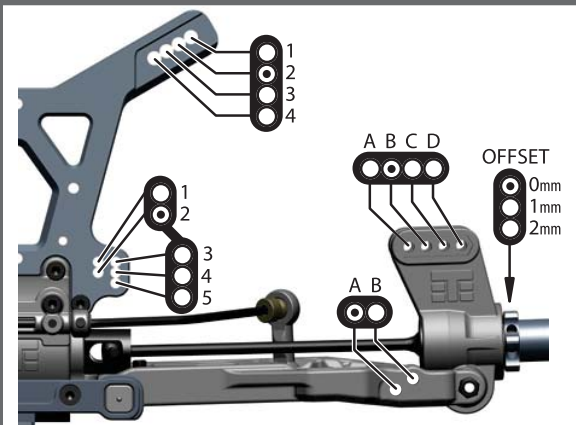

"C" Block
(2° WITH CENTER DOT INSERT)

(Anti-Squat)



"D" Block
(3° WITH CENTER DOT INSERT)

(Rear Toe)

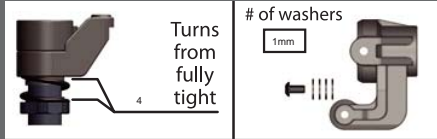

Suspension:

	FRONT	REAR
RIDE HEIGHT	28mm	28mm
CAMBER	-1	-2
CASTER	15	
SWEEP	0	
KICK UP	10	
ANTI-SQUAT		2
TOE (in/out)	1 out	3 in
SWAY BAR	2.5	2.5
SHOCK LENGTH (DROOP)	118.5mm	134.5mm

Body/Wing:

BODY MAKE	Tekno
WING MAKE	Tekno, drilled out

POSITION SETTINGS

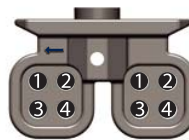

- 1 - REARWARD LOW
- 2 - FOREWARD LOW
- 3 - REARWARD HIGH
- 4 - FOREWARD HIGH

DOWNFORCE SETTINGS

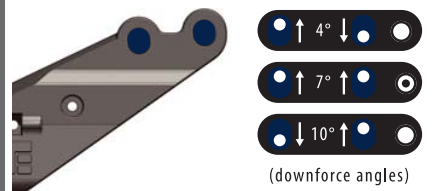

Wheelbase:

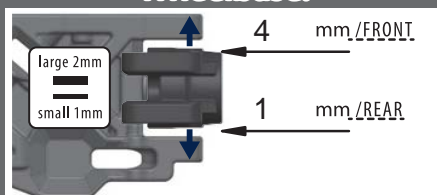

Shocks:

	FRONT	REAR
OIL	500	550
BRAND		
PISTON	4.8 taper	4.8 taper
SPRING	Yellow	Blue
REBOUND	5 %	5 %
STD/EMUL/VENT	STD	STD

NOTES:

Tires/Wheels:

	FRONT	REAR
BRAND/TREAD	PL/Holesh	PL/Holesh
COMPOUND	X3/X2	X3/X2
INSERT	PL	PL
WHEEL	PL	PL

NOTES: X3 when wet, X2 when

Differential Oil:

	FRONT	CENTER	REAR
	5k	7k	3k

Equipment:

ENGINE/PIPE:	Novarossi / Novarossi
PLUG:	Novarossi C6TGC
FUEL:	Punch 30%
RX BATT:	850mah Li-Ion (mount)
SERVOS:	(steering) Highest / (throttle/brake) Highest

Drivetrain:

CLUTCH/SPUR:	16 / 44 (teeth)
CLUTCH SHOES:	Tekno (4 aluminum)
CLUTCH SPRINGS:	2 green / 2 red
BRAKE BIAS:	(front) 45 % / (rear) 55 %

Chassis Braces:

Center <input type="checkbox"/> Left Rear <input type="checkbox"/> Right Rear <input type="checkbox"/>
(front brace is always recommended)

Notes:

3241g total weight, 46.5% front