

Name: Jared Wiggins

Date: 8/3/15

Event: Futaba OS Nitro Challenge

Track: Indoor Outdoor **Size:** Small Medium Large **Traction:** Low Med High

Surface: Smooth Bumpy Rutted **Type:** Loose/Loamy Hard Pack Blue Groove Clay

Bumpsteer/Ackerman/Servo Saver/Steering Stop:

Condition: Dusty Dry Wet Muddy



Front End:

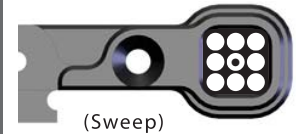
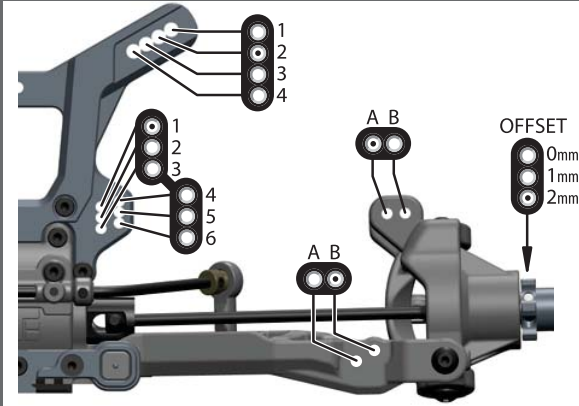

"A" Block
(0° WITH CENTER DOT INSERT)

(Sweep)



"B" Block
(10° WITH CENTER DOT INSERT)

(Kick Up)

Rear End:

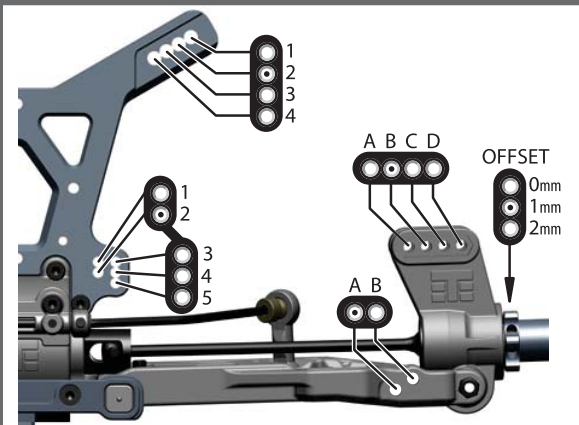

"C" Block
(2° WITH CENTER DOT INSERT)

(Anti-Squat)



"D" Block
(3° WITH CENTER DOT INSERT)

(Rear Toe)

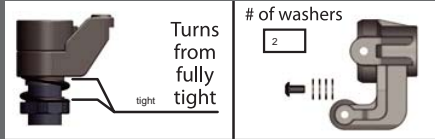

Suspension:

	FRONT	REAR
RIDE HEIGHT	27	28
CAMBER	-2	-2.5
CASTER	15	
SWEEP	0	
KICK UP	9	
ANTI-SQUAT		2
TOE (in/out)	1 out	3 in
SWAY BAR	2.5	2.6
SHOCK LENGTH (DROOP)	123mm	137mm

Body/Wing:

BODY MAKE	Tekno
WING MAKE	Tekno

POSITION SETTINGS

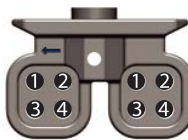

- 1 - REARWARD LOW
- 2 - FOREWARD LOW
- 3 - REARWARD HIGH
- 4 - FOREWARD HIGH

DOWNFORCE SETTINGS

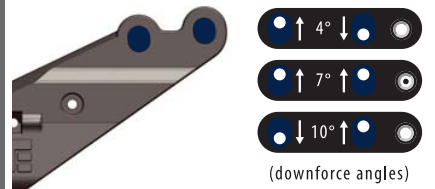

Wheelbase:

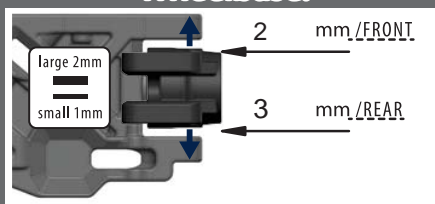

Shocks:

	FRONT	REAR
OIL	450	475
BRAND	Pt racing	Pt racing
PISTON	4-1.85	4-1.85
SPRING	pink	orange
REBOUND	25 %	25 %
STD/EMUL/VENT	vent	vent

NOTES: 90-95 degrees

Tires/Wheels:

	FRONT	REAR
BRAND/TREAD	catapult	catapult
COMPOUND	med	med
INSERT	aka red	aka red
WHEEL	aka	aka

NOTES:

Differential Oil:

	FRONT	CENTER	REAR
5k	5k	4k	

Equipment:

ENGINE/PIPE:	Triton L4 /2120
PLUG:	Triton #5
FUEL:	Byrons 30-9
RX BATT:	Protek 1800 Life
SERVOS:	(steering) Airtronics / (throttle/brake) Airtronics

Drivetrain:

CLUTCH/SPUR:	46 / 15 (teeth)
CLUTCH SHOES:	Aluminum
CLUTCH SPRINGS:	1.0
BRAKE BIAS:	(front) 65 % / (rear) 35 %

Chassis Braces:

Center <input type="checkbox"/> Left Rear <input type="checkbox"/> Right Rear <input type="checkbox"/>
(front brace is always recommended)

Notes:

Very bumpy/blownout, .2 front spindles