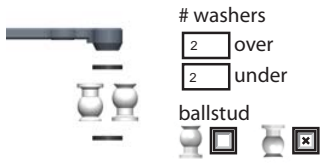
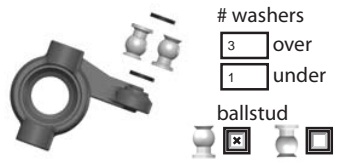
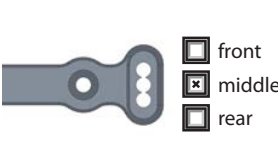

Name: Chad Roland

Date: June 28-29th Event/Track: Serpent Challenge at McCullough's

Track Conditions: Outdoor Indoor Wet Dry High Bite Low Bite Rough
 Smooth Hard Packed Loose/Loamy Blue Groove

Bumpsteer/Ackerman/Servo Saver/Steering Stop:

 <p># washers 2 over 2 under ballstud <input type="checkbox"/></p>	 <p># washers 3 over 1 under ballstud <input checked="" type="checkbox"/></p>	 <p><input type="checkbox"/> front <input checked="" type="checkbox"/> middle <input type="checkbox"/> rear</p>
---	---	---

Front End:

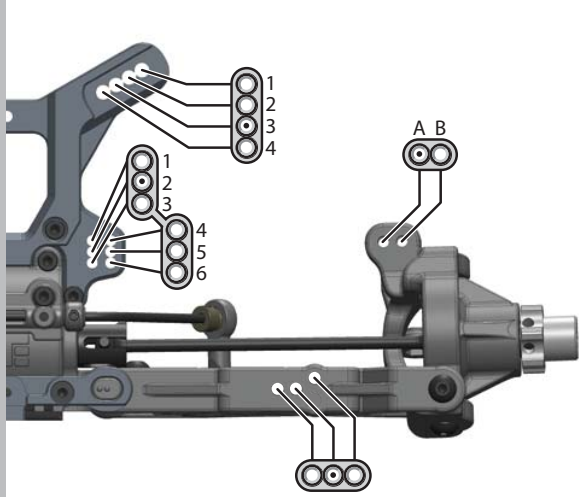

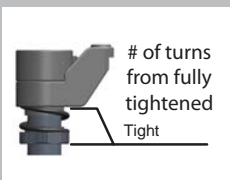
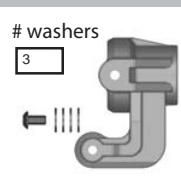
 <p># of turns from fully tightened Tight</p>	 <p># washers 3</p>
--	--

Suspension:

	FRONT	REAR
RISE HEIGHT:	35	37
TOE (in/out):	-1.5	3
CAMBER:	-1.5	2
CASTER:	15 Deg°	
SHOCK LENGTH (DROOP):	118	131
SWAY BAR:	2.5	2.4

NOTES:

Body/Wing:

BODY:	Stock
WING:	Upgrade Vortex

Front Outer (Sweep)

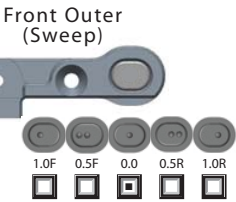

1.0F 0.5F 0.0 0.5R 1.0R

Front Inner (Kick Up)

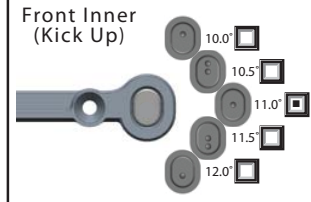

10.0° 10.5° 11.0° 11.5° 12.0°

Rear End:

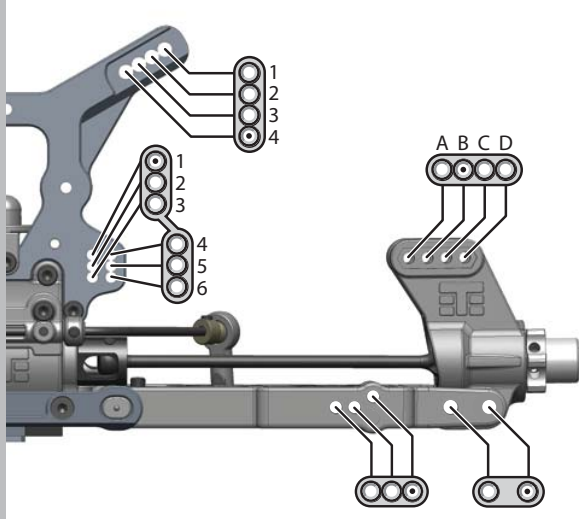
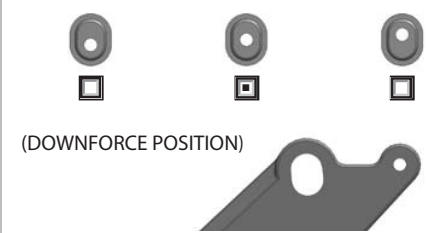
(DOWNFORCE POSITION)

Wheelbase:

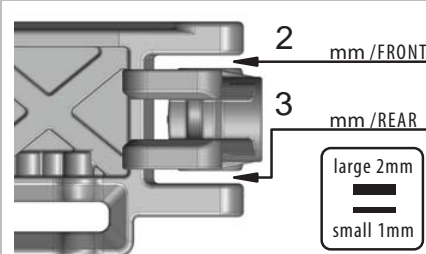

Rear Outer (Toe In)



2.5° 3.0° 3.5° 4.0° 4.5°

Rear Inner (Anti-Squat)

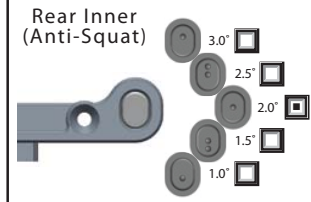

3.0° 2.5° 2.0° 1.5° 1.0°

Notes:

The truggy handled all types of conditions from groove, blue groove and even on a wet surface. Truck was very predictable.

Shocks:

	FRONT	REAR
STD/EMUL/VENT:	STD	STD
PISTON:	8X1.3	8X1.3
OIL:	45AE	40AE
BLADDER:	Stock	Stock
REBOUND:	0 %	0 %
SPRING:	Green	Green

NOTES:

Tires / Wheels:

	FRONT	REAR
BRAND:	HB	HB
TREAD:	Megabite	Megabite
COMPOUND:	Pink	Pink
INSERT:	AKA Red	AKA Red
WHEEL:	AKA	AKA

NOTES:

Differential Oil:

	FRONT	CENTER	REAR
	10	15	7

NOTES:

Equipment:

BATTERY:	SMC 6500 70C
ESC:	RX8
MOTOR:	T8 2050
RADIO:	
SERVO(s):	

NOTES:

Drivetrain:

PINION/BELL:	15 (teeth)
SPUR GEAR:	Metal <input type="checkbox"/> Plastic <input type="checkbox"/>
BRAKES:	Mech <input type="checkbox"/> Motor <input type="checkbox"/>
TRAKTION DRIVE:	N ^{Y/N} / Springs

NOTES: Finished 2nd in the A-main.