



Name: Devin Chesney Date: 9-27-14 Event/Track: Northeast Showdown @ LCRC

Track Conditions: Outdoor Indoor Wet Dry High Bite Low Bite Rough
 Smooth Hard Packed Loose/Loamy Blue Groove

Bumpsteer/Ackerman/Servo Saver/Steering Stop:

 <p># washers <input type="checkbox"/> over <input type="checkbox"/> under ballstud <input type="checkbox"/> <input checked="" type="checkbox"/></p>	 <p># washers <input type="checkbox"/> over <input checked="" type="checkbox"/> under ballstud <input type="checkbox"/> <input checked="" type="checkbox"/></p>	 <p><input type="checkbox"/> front <input type="checkbox"/> middle <input checked="" type="checkbox"/> rear</p>
--	--	---

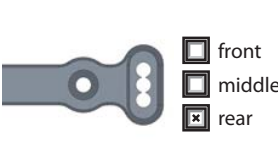
Front End:

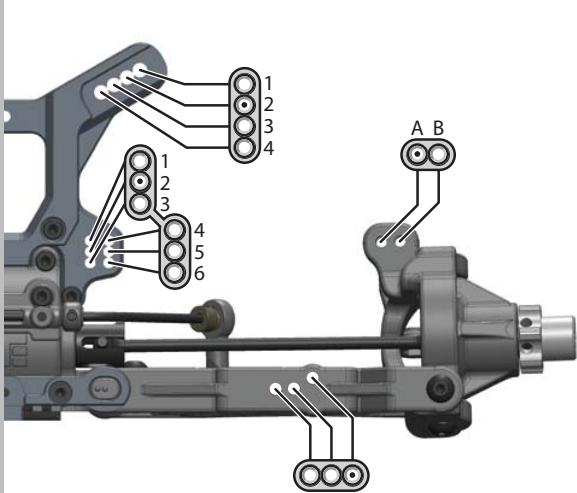

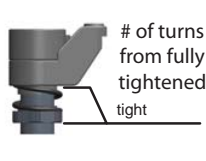
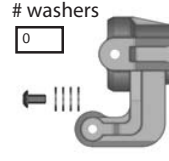
 <p># of turns from fully tightened tight</p>	 <p># washers <input type="checkbox"/> <input checked="" type="checkbox"/></p>
--	---

Suspension:

	FRONT	REAR
RIDE HEIGHT:	27	27
TOE (in/out):	1 out	3 in
CAMBER:	-2	-2
CASTER:	10 Deg°	
SHOCK LENGTH (DROOP):	106	122
SWAY BAR:	2.4	2.6

NOTES:

Body/Wing:

BODY:	tekno
WING:	tekno

(DOWNFORCE POSITION)

Wheelbase:

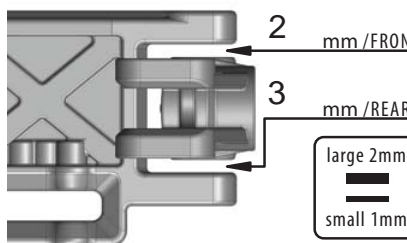

Notes:

LW +1 rear hexes
 LW front hexes

Shocks:

	FRONT	REAR
STD/EMUL/VENT:	vented	vented
PISTON:	6x1.5	6x1.5
OIL:	37.5	30
BLADDER:	stock	stock
REBOUND:	0 %	0 %
SPRING:	pink	red

NOTES:

Tires / Wheels:

	FRONT	REAR
BRAND:	PL	PL
TREAD:	Lockdown	Lockdown
COMPOUND:	X3	X3
INSERT:	Blue	Blue
WHEEL:	PL	

NOTES:

Differential Oil:

	FRONT	CENTER	REAR
	7	7	5

NOTES:

Equipment:

BATTERY:	Venom
ESC:	HW 150A
MOTOR:	Tekin T8 1900
RADIO:	Futaba 4PL
SERVO(s):	Savox

NOTES:

Drivetrain:

PINION/BELL:	17	(teeth)
SPUR GEAR:	Metal <input type="checkbox"/>	Plastic <input checked="" type="checkbox"/>
BRAKES:	Mech <input type="checkbox"/>	Motor <input checked="" type="checkbox"/>
TRAKTION DRIVE:	Y/N	/ Springs

NOTES:

Front Outer (Sweep)

1.0F 0.5F 0.0 0.5R 1.0R

Front Inner (Kick Up)

10.0° 10.5° 11.0° 11.5° 12.0°

Rear End:

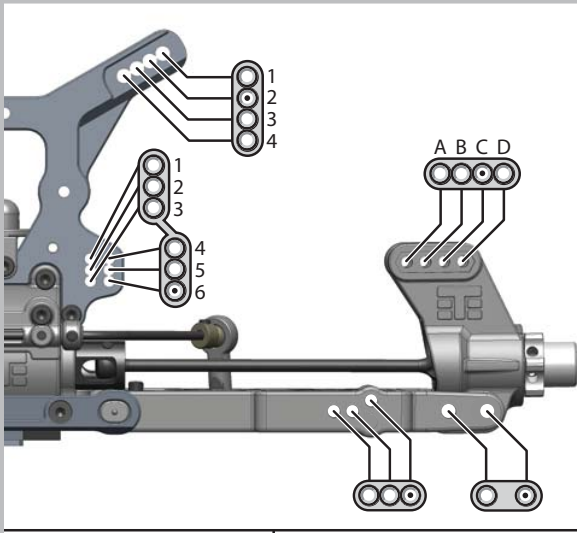

Rear Outer (Toe In)

2.5° 3.0° 3.5° 4.0° 4.5°

Rear Inner (Anti-Squat)

3.0° 2.5° 2.0° 1.5° 1.0°