



Name: Joe Bornhorst Date: 9-14-2014 Event/Track: Race Against Cancer/McCulloughs

Track Conditions: Outdoor  Indoor  Wet  Dry  High Bite  Low Bite  Rough   
 Smooth  Hard Packed  Loose/Loamy  Blue Groove

### Bumpsteer/Ackerman/Servo Saver/Steering Stop:

 <p># washers  <input type="checkbox"/> over  <input type="checkbox"/> under                  ballstud  <input type="checkbox"/> <input checked="" type="checkbox"/></p>	 <p># washers  <input type="checkbox"/> over  <input type="checkbox"/> under                  ballstud  <input type="checkbox"/> <input checked="" type="checkbox"/></p>	 <p><input type="checkbox"/> front  <input type="checkbox"/> middle  <input checked="" type="checkbox"/> rear</p>
--	---	--

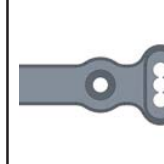
### Front End:

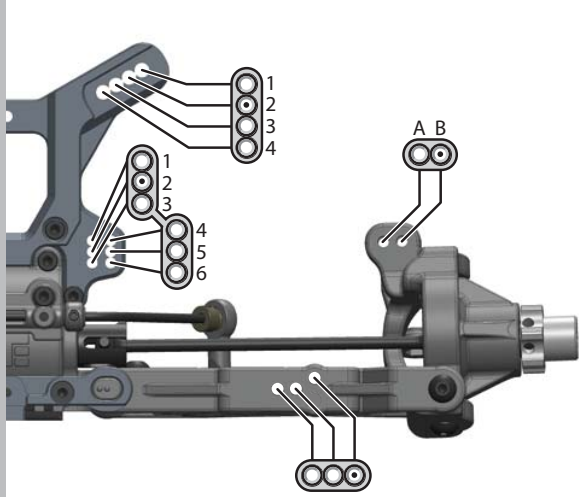

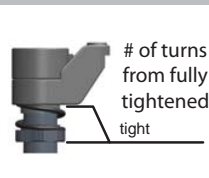
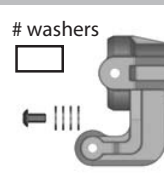
 <p># of turns from fully tightened tight</p>	 <p># washers  <input type="checkbox"/></p>
--	---

### Suspension:

	FRONT	REAR
RISE HEIGHT:	27	27
TOE (in/out):	1	3.5
CAMBER:	-2	-2
CASTER:	10 Deg°	
SHOCK LENGTH (DROOP):	106	122
SWAY BAR:	2.4	2.6

NOTES:

### Body/Wing:

BODY:	Tekno
WING:	Tekno

(DOWNFORCE POSITION)

### Wheelbase:

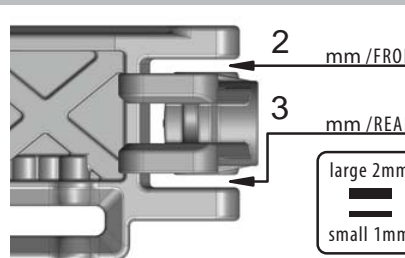

### Notes:

Delrin shock internals/TiNi shock shafts.  
 Worked in all conditions- Wet or dry.  
 This setup has a lot of steering.

### Shocks:

	FRONT	REAR
STD/EMUL/VENT:	vent	vent
PISTON:	6x1.5	6x1.5
OIL:	450	350
BLADDER:	std	std
REBOUND:	0 %	0 %
SPRING:	Pink	Red

NOTES:

### Tires / Wheels:

	FRONT	REAR
BRAND:	AKA	AKA
TREAD:	Gridiron II	Gridiron II
COMPOUND:	SS	SS
INSERT:	Red	Red
WHEEL:	AKA Evo	AKA Evo

NOTES:

### Differential Oil:

	FRONT	CENTER	REAR
	7k	7k	5k

NOTES:

### Equipment:

BATTERY:	SMC 6500
ESC:	Tekin RX8 Gen2
MOTOR:	Tekin Gen2 T8 1900kv
RADIO:	Airtronics
SERVO(s):	Savox 1270

NOTES:

### Drivetrain:

PINION/BELL:	19 (teeth)
SPUR GEAR:	Metal <input type="checkbox"/> Plastic <input type="checkbox"/>
BRAKES:	Mech <input type="checkbox"/> Motor <input type="checkbox"/>
TRAKTION DRIVE:	Y/N / Springs

NOTES:

### Front Outer (Sweep)

1.0F 0.5F 0.0 0.5R 1.0R

### Front Inner (Kick Up)

10.0 10.5 11.0 11.5 12.0

### Rear End:

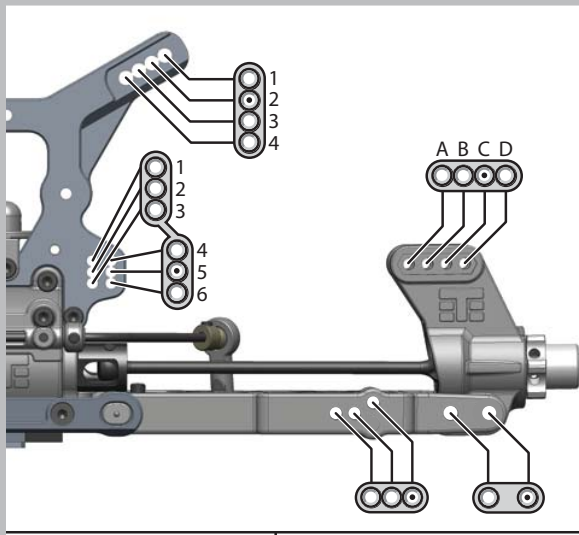

### Rear Outer (Toe In)

2.5 3.0 3.5 4.0 4.5

### Rear Inner (Anti-Squat)

3.0 2.5 2.0 1.5 1.0