



Name: Edwin Hartman Date: 8/30/2014 Event/Track: 439 Raceway

Track Conditions: Outdoor Indoor Wet Dry High Bite Low Bite Rough
 Smooth Hard Packed Loose/Loamy Blue Groove

Bumpsteer/Ackerman/Servo Saver/Steering Stop:

 <p># washers 2 over 2 under ballstud <input type="checkbox"/> <input checked="" type="checkbox"/></p>	 <p># washers 4 over 0 under ballstud <input checked="" type="checkbox"/> <input type="checkbox"/></p>	 <p><input type="checkbox"/> front <input type="checkbox"/> middle <input checked="" type="checkbox"/> rear</p>
---	--	--

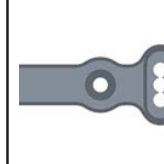
Front End:

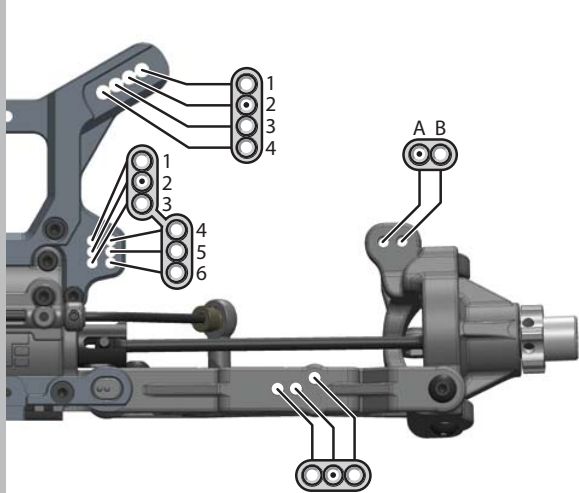

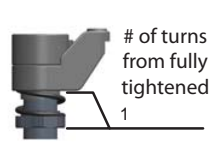
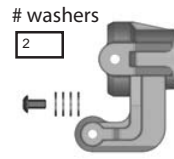
 <p># of turns from fully tightened 1</p>	 <p># washers 2</p>
--	---

Suspension:

	FRONT	REAR
RISE HEIGHT:	28	28
TOE (in/out):	1.5	
CAMBER:	2	2
CASTER:	15 Deg°	
SHOCK LENGTH (DROOP):		
SWAY BAR:	2.5	2.4

NOTES:

Body/Wing:

BODY:	Tekno
WING:	Tekno

(DOWNFORCE POSITION)

Wheelbase:

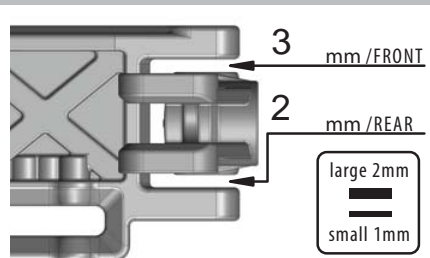

Notes:

LRC
 TQ and Fastest lap on the day

Shocks:

	FRONT	REAR
STD/EMUL/VENT:	STD	STD
PISTON:	8x1.3	8x1.3
OIL:	450	400
BLADDER:	STD	STD
REBOUND:	20 %	20 %
SPRING:	Pink	Red

NOTES: 2 o-rings on each shock to limit up-travel

Tires / Wheels:

	FRONT	REAR
BRAND:	Pro-Line	Pro-Line
TREAD:	Blockade	Blockade
COMPOUND:	X2	X2
INSERT:	PL	PL
WHEEL:	PL	PL

NOTES:

Differential Oil:

	FRONT	CENTER	REAR
	7,000	7,000	3,000

NOTES:

Equipment:

BATTERY:	TrakPower 90C
ESC:	Toro TS150
MOTOR:	Toro X8S 1750
RADIO:	Futaba 4PKS
SERVO(s):	Futaba BLS351

NOTES:

Drivetrain:

PINION/BELL:	19 (teeth)
SPUR GEAR:	Metal <input type="checkbox"/> Plastic <input type="checkbox"/>
BRAKES:	Mech <input type="checkbox"/> Motor <input type="checkbox"/>
TRAKTION DRIVE:	N ^{Y/N} / Springs

NOTES:

Front Outer (Sweep)

1.0F 0.5F 0.0 0.5R 1.0R

Front Inner (Kick Up)

10.0 10.5 11.0 11.5 12.0

Rear End:

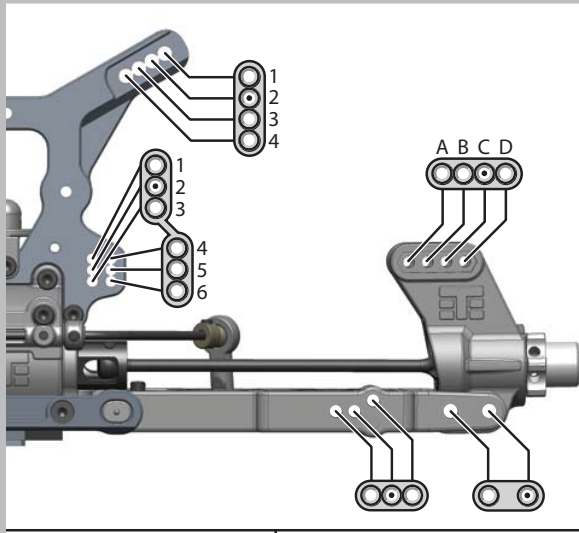

Rear Outer (Toe In)

2.5 3.0 3.5 4.0 4.5

Rear Inner (Anti-Squat)

3.0 2.5 2.0 1.5 1.0