



Name: Mason Eppley Date: 7/19/14 Event/Track: N.C.S.O.S/ Crown Raceway

Track Conditions: Outdoor Indoor Wet Dry High Bite Low Bite Rough
 Smooth Hard Packed Loose/Loamy Blue Groove

Bumpsteer/Ackerman/Servo Saver/Steering Stop:

 <p># washers <input type="checkbox"/> over <input checked="" type="checkbox"/> under ballstud <input type="checkbox"/> <input checked="" type="checkbox"/></p>	 <p># washers <input checked="" type="checkbox"/> over <input type="checkbox"/> under ballstud <input checked="" type="checkbox"/> <input type="checkbox"/></p>	 <p><input type="checkbox"/> front <input checked="" type="checkbox"/> middle <input type="checkbox"/> rear</p>
-------------------------------------------------------------------------------------------------------------------------------------------------------------------------------------------------------------------------------------------------------------------------------------	--------------------------------------------------------------------------------------------------------------------------------------------------------------------------------------------------------------------------------------------------------------------------------------	------------------------------------------------------------------------------------------------------------------------------------------------------------------------------------------------------------

Front End:

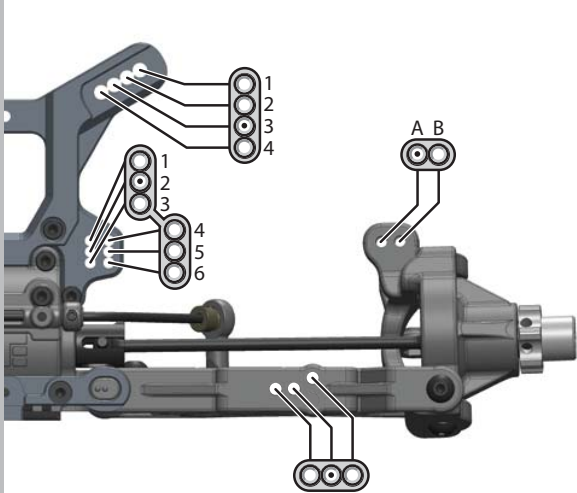

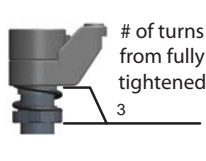
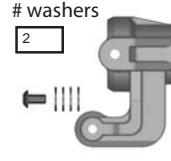
 <p># of turns from fully tightened <input type="checkbox"/> 3</p>	 <p># washers <input type="checkbox"/> 2</p>
----------------------------------------------------------------------------------------------------------------------------------------------------------	-------------------------------------------------------------------------------------------------------------------------------------

Suspension:

	FRONT	REAR
RIDE HEIGHT:	27	28
TOE (in/out):	1	3
CAMBER:	1.5	1.5
CASTER:	15 Deg°	
SHOCK LENGTH (DROOP):	105	120
SWAY BAR:	2.5	2.6

NOTES:

Body/Wing:

BODY:	PL Phantom
WING:	Upgrade Vortex

(DOWNFORCE POSITION)

Wheelbase:

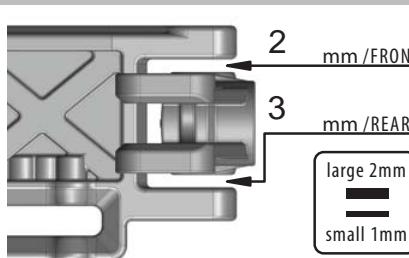

Notes:

LRC brace used

Shocks:

	FRONT	REAR
STD/EMUL/VENT:	STD	STD
PISTON:	10x1.2	10x1.2
OIL:	35wt	35wt
BLADDER:	STK	STK
REBOUND:	25 %	25 %
SPRING:	Pink	Red

NOTES: TLR Oil

Tires / Wheels:

	FRONT	REAR
BRAND:	AKA	AKA
TREAD:	Impacts	Impacts
COMPOUND:	SS	SS
INSERT:	Red	Red
WHEEL:	Speedline	Speedline

NOTES:

Differential Oil:

	FRONT	CENTER	REAR
5K	5K	5K	5K

NOTES: TLR Oil

Equipment:

BATTERY:	SMC 6500 70c
ESC:	RX8 Gen2
MOTOR:	T8 Gen2 1900
RADIO:	M12
SERVO(s):	150T

NOTES:

Drivetrain:

PINION/BELL:	18	(teeth)
SPUR GEAR:	Metal <input type="checkbox"/>	Plastic <input type="checkbox"/>
BRAKES:	Mech <input type="checkbox"/>	Motor <input type="checkbox"/>
TRAKTION DRIVE:	Y/N	/ Springs

NOTES:

Front Outer (Sweep)

1.0F 0.5F 0.0 0.5R 1.0R

Front Inner (Kick Up)

10.0" 10.5" 11.0" 11.5" 12.0"

Rear End:

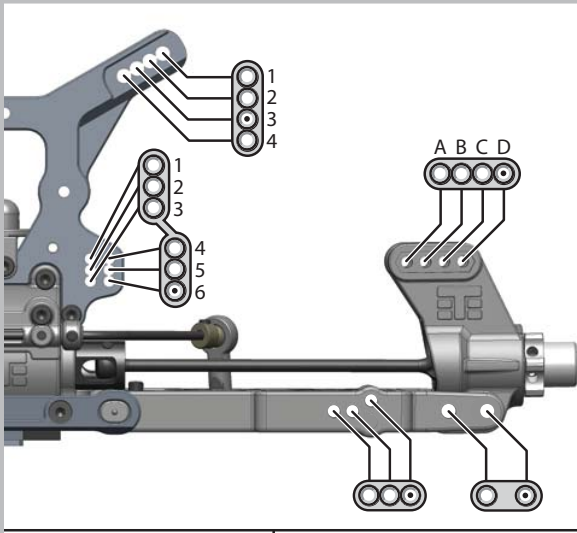

Rear Outer (Toe In)

2.5" 3.0" 3.5" 4.0" 4.5"

Rear Inner (Anti-Squat)

3.0" 2.5" 2.0" 1.5" 1.0"