

Name: Mark Unrath

Date: 2/16/14

Event/Track: Motorama

Track Conditions: Outdoor Indoor Wet Dry High Bite Low Bite Rough
 Smooth Hard Packed Loose/Loamy Blue Groove

Bumpsteer/Ackerman/Servo Saver/Steering Stop:

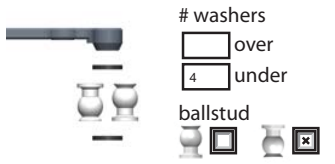
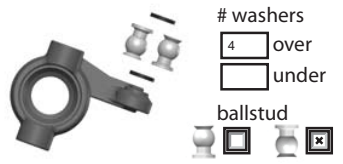
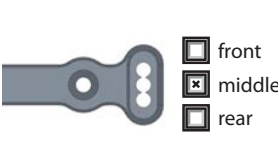
 <p># washers <input type="checkbox"/> over <input checked="" type="checkbox"/> 4 under ballstud <input type="checkbox"/> <input checked="" type="checkbox"/></p>	 <p># washers <input type="checkbox"/> over <input checked="" type="checkbox"/> 4 under ballstud <input type="checkbox"/> <input checked="" type="checkbox"/></p>	 <p><input type="checkbox"/> front <input checked="" type="checkbox"/> middle <input type="checkbox"/> rear</p>
---	--	---

Front End:

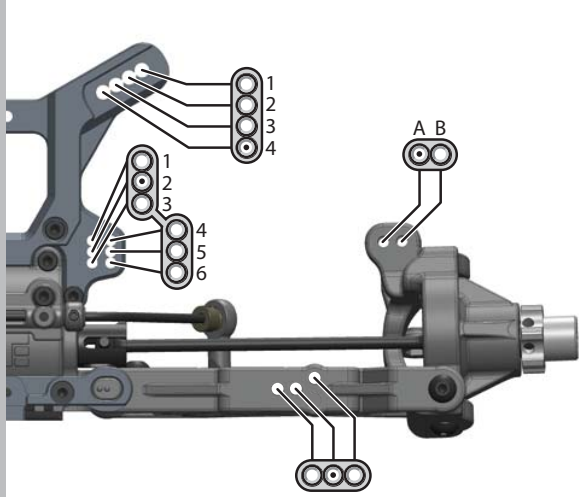

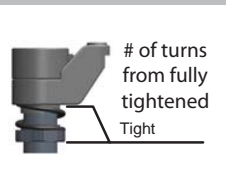
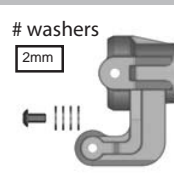
 <p># of turns from fully tightened Tight</p>	 <p># washers <input checked="" type="checkbox"/> 2mm</p>
--	--

Suspension:

	FRONT	REAR
RIDE HEIGHT:	27	28
TOE (in/out):	1 out	4
CAMBER:	1.5	2
CASTER:	STK Deg°	
SHOCK LENGTH (DROOP):	105	121
SWAY BAR:	2.3	2.4

NOTES: Will go back to 2.5 rear sway bar

Body/Wing:

BODY:	JC Finisher
WING:	JC Finisher

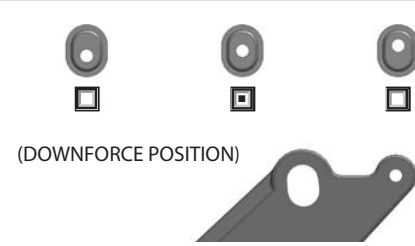

(DOWNFORCE POSITION)

Wheelbase:

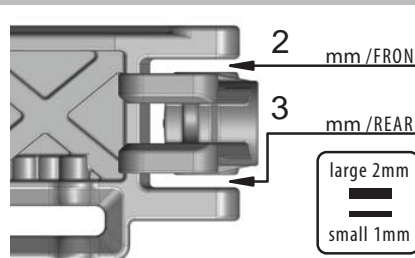

Notes:

- Used BMI LRC Rear toe blocks.
- Used lightweight +1 Rear wheel hex
- Used lightweight front wheel hex

Shocks:

	FRONT	REAR
STD/EMUL/VENT:	STD	STD
PISTON:	CSI Blue	CSI Blue
OIL:	L 40	L 35
BLADDER:	STK	STK
REBOUND:	0 %	0 %
SPRING:	K Blue	K Orange

NOTES:

Tires / Wheels:

	FRONT	REAR
BRAND:	JC	JC
TREAD:	Hybrid	Hybrid
COMPOUND:	SS	SS
INSERT:	STK	STK
WHEEL:	bullet	Bullet

NOTES:

Differential Oil:

FRONT	CENTER	REAR
7	5	3

NOTES:

Equipment:

BATTERY:	Pro-Matc
ESC:	Tekin RX8 Gen2
MOTOR:	Tekin Gen 2 1900
RADIO:	Radiopost TS401
SERVO(s):	Radiopost Red

NOTES:

Drivetrain:

PINION/BELL:	19/44	(teeth)
SPUR GEAR:	Metal <input type="checkbox"/>	Plastic <input checked="" type="checkbox"/>
BRAKES:	Mech <input type="checkbox"/>	Motor <input checked="" type="checkbox"/>
TRAKTION DRIVE:	Y/N	/ Springs

NOTES:

Front Outer (Sweep)

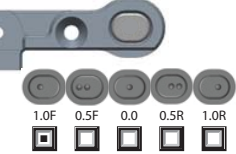

1.0F 0.5F 0.0 0.5R 1.0R

Front Inner (Kick Up)



10.0° 10.5° 11.0° 11.5° 12.0°

Rear End:

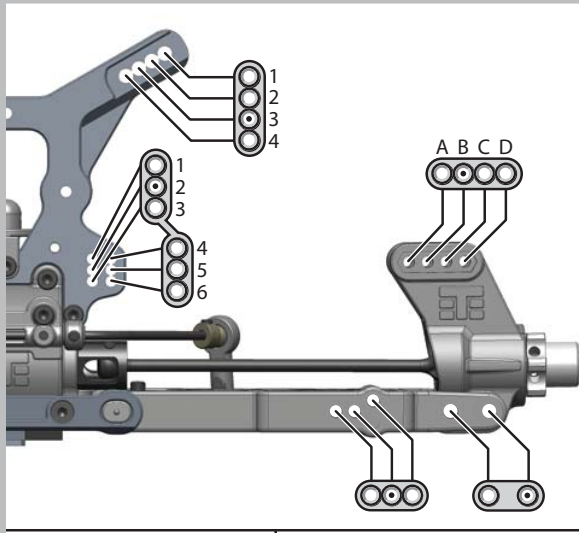

Rear Outer (Toe In)

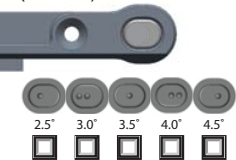

2.5° 3.0° 3.5° 4.0° 4.5°

Rear Inner (Anti-Squat)



3.0° 2.5° 2.0° 1.5° 1.0°