

SETUP SHEET

Name: Curtis Door Date: _____ Event: _____

Track Conditions: Outdoor Open Loose/Loamy Dusty High Bite Low Bite Rough
 Indoor Tight Smooth Hard Packed Wet Dry Med Bite Blue Groove

BUMPSTEER/ACKERMANN/SERVO SAVER



SHOCKS

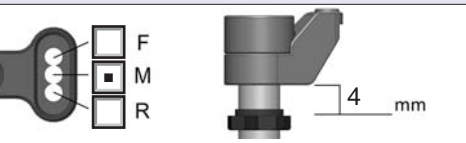

FRONT

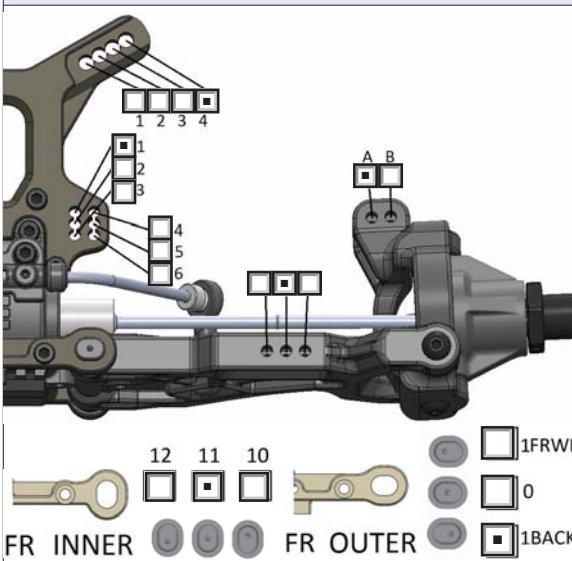

SUSPENSION

| | Front | Rear |
|-------------|-------|------|
| Ride Height | 26 | 28 |
| Camber | 2 | 3 |
| Toe | 1 out | 4 in |
| Sway Bar | 2.5 | 2.2 |

SHOCKS

| | Front | Rear |
|--------------|----------------|------------|
| Piston | Kyo 1.3x8 | Kyo 1.3x8 |
| Oil | 40 Losi | 30 Losi |
| Bladder | Standard | Standard |
| Spring | Kyo Light Blue | Kyo Orange |
| Length/Droop | 105 | 122 |

REAR

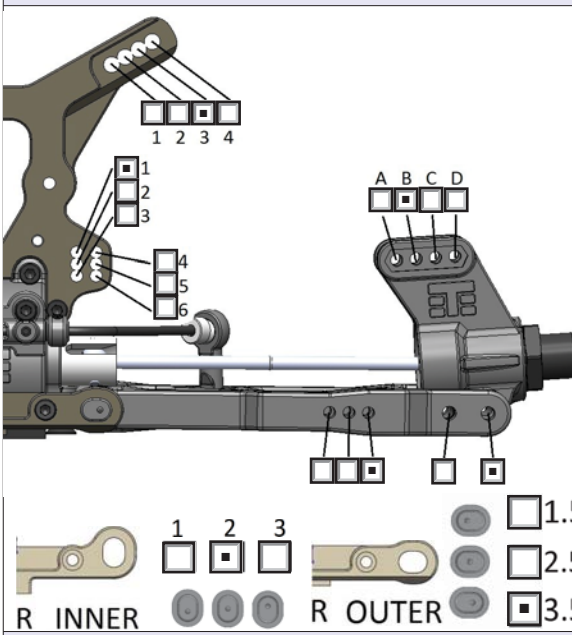

WING

Brand: UpGrade

Type: Vortex

TIRES

| | Front | Rear |
|----------|--------------|--------------|
| Brand | P-L Blockade | P-L Blockade |
| Compound | M3 | M3 |
| Insert | Standard | Standard |
| Wheel | Velocity | Velocity |

BRACES

Front Middle Rear
 (Front is always recommended)

Notes:

WHEELBASE

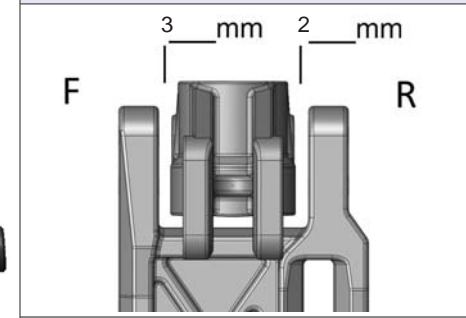

DIFFS

| Front | Center | Rear |
|-------|--------|------|
| 7K | 5K | 5K |

ELECTRONICS

ESC: Tekin RX8
 Battery: ProTek 6700 100C
 Servo(s): ProTek 150S
 Radio: Airtronics M12
 Motor: Tekin 2050KV

DRIVETRAIN

Gear Ratio: 17 / 44

Pinion Long Shank
 Traktion Clutch

Mech. Brake Motor Brake

Spur: Metal Plastic

Shoes: _____

Springs: _____

NOTES:

+2mm front hexes, +1 rears. Rear shocks in upper outer hole with new arms. All lightweight parts used.